

# CATALOGO 2026

 SINED

DESIGN-FUOCO

*INDOOR OUTDOOR  
ITALIAN DESIGN  
MILANO | BARCELONA*

catalogo  
digitale





### Chi siamo

Nel **1996** nasce **MPC Srl**, un'azienda italiana dedicata alla vendita online di marchi prestigiosi. Nel **2020**, spinti dal desiderio di creare prodotti unici nel design e insuperabili nella qualità, **Alberto Musso e Denis Gottifredi** lanciano il brand **SINED**. Fin dalla nascita, SINED si distingue per **l'unicità dei suoi prodotti**, frutto di una continua ricerca estetica, tecnica e funzionale. Oggi Sined è un marchio di riferimento in **Italia, Spagna** e in numerosi altri paesi, specializzato nella produzione di **caminetti elettrici e riscaldatori infrarossi**.

### Il nostro valore

"Impegno costante e professionalità hanno reso il marchio riconosciuto per l'attenzione ai dettagli, il design innovativo e l'impiego di materiali di eccellenza."

### Distribuzione

La nostra rete distributiva si rivolge a:

- Progettisti, architetti e costruttori
- Negozi di termoidraulica e arredo bagno con showroom
- Installatori di piscine
- Professionisti del settore outdoor e dell'interior design

### About Us

In **1996**, **MPC Srl** was founded as a company dedicated to the online sale of prestigious brands. In **2020**, driven by the desire to create products that are unique in design and unmatched in quality, **Alberto Musso and Denis Gottifredi** launched the **SINED** brand. From its inception, SINED has stood out for **the originality of its products**, the result of continuous aesthetic, technical, and functional research. Today, SINED is a leading brand in **Italy, Spain**, and many other countries all over the world, specializing in the production of **electric fireplaces and infrared heaters**.

### Our Value

"Ongoing commitment and professionalism have made the brand renowned for its attention to detail, innovative design, and use of premium-quality materials."

### Distribution

Our distribution network serves:

- Designers, architects, and builders
- Plumbing and bathroom furnishing stores with showrooms
- Pool installation professionals
- Outdoor and interior design specialists

# OUR COMMITMENT TO THE ENVIRONMENT

At SINED, sustainability is not an abstract concept, but a concrete responsibility that drives every one of our decisions.

We believe that designing and manufacturing with respect for the planet means actively contributing to a better future for all.

Sustainability is a fundamental part of our corporate identity.

Our environmental goals are translated into tangible, measurable actions:

- **Fostering a sustainable culture** that engages every team member and attracts talents motivated to make a positive impact.  
All our staff work remotely, helping reduce emissions related to commuting, lower office energy consumption, and minimize the overall environmental footprint of our operations.
- Developing durable and responsible products that meet customer needs through low-impact solutions.  
We are putting an end to the disposable mindset: our products are designed to stand the test of time, not to be replaced.  
Through thoughtful design and easy reparability, we reduce waste, eliminate hidden costs, and lower avoidable environmental impacts.
- Embedding sustainability principles into our strategic vision, ensuring their practical implementation in operations and shared goals.

Promoting a conscious and innovative leadership, capable of driving the transition toward a greener economy, while empowering the younger generation and embracing fresh ideas for sustainable change.

**We believe sustainability must be expressed through concrete, measurable choices. That's why every detail in our products and processes reflects our responsible vision and the desire to create real, lasting impact.**

- **Products built to last:** they are not just functional components, but long-lasting, reliable solutions designed to minimize the need for replacements and promote more responsible resource use.
- **Solutions made for real life:** each of our products is shaped by listening to people and understanding their actual needs.  
Design, functionality, and aesthetics come together to deliver versatile, elegant solutions that fit seamlessly into contemporary living spaces.
- **A concrete commitment to reducing environmental impact:** we carefully select materials and employ advanced, responsible production processes to minimize our ecological footprint and foster a more sustainable development model.

# IL NOSTRO IMPEGNO PER L'AMBIENTE

In SINED, la sostenibilità non è un concetto astratto, ma una responsabilità concreta che guida ogni nostra scelta.

Crediamo che progettare e produrre con rispetto per il pianeta significhi contribuire attivamente a un futuro migliore per tutti.

La sostenibilità è parte integrante della nostra identità aziendale.

I nostri obiettivi ambientali si traducono in azioni reali e misurabili:

- **Diffondere una cultura sostenibile** che coinvolga ogni collaboratore e attragga talenti orientati al cambiamento positivo.  
Tutto il nostro personale opera in modalità *smartworking*, contribuendo a ridurre le emissioni legate agli spostamenti, il consumo energetico degli uffici e l'impatto ambientale complessivo della struttura operativa.
- Sviluppare prodotti durevoli e responsabili, in grado di soddisfare le esigenze dei clienti con soluzioni a basso impatto.  
Mettiamo fine alla logica dell'usa e getta: i nostri prodotti sono concepiti per accompagnare il tempo, non per essere sostituiti.  
Grazie a una progettazione attenta e alla scelta dei materiali, riduciamo gli sprechi, abbattiamo costi superflui e minimizziamo gli impatti ambientali evitabili.
- Incorporare i principi di sostenibilità nella visione strategica dell'azienda, assicurandone l'applicazione concreta nelle scelte operative e negli obiettivi comuni.

Promuovere una leadership consapevole e innovativa, capace di guidare la trasformazione verso un'economia più verde, valorizzando il contributo delle nuove generazioni e dando spazio a giovani con idee sostenibili e visioni orientate al cambiamento positivo.

**Crediamo che la sostenibilità debba tradursi in scelte concrete, tangibili e misurabili. Per questo, ogni dettaglio dei nostri prodotti e processi riflette la nostra visione responsabile e il desiderio di generare un impatto positivo reale.**

- **Prodotti pensati per durare nel tempo:** non sono semplici elementi funzionali, ma soluzioni progettate per offrire lunga durata, alta affidabilità e ridurre la necessità di frequenti sostituzioni, contribuendo così a un uso più consapevole delle risorse.
- **Soluzioni concepite per migliorare la vita quotidiana:** ogni nostro prodotto nasce dall'ascolto delle persone e dei loro bisogni reali. Design, funzionalità ed estetica si uniscono per creare soluzioni versatili, eleganti e perfettamente integrate negli ambienti contemporanei.
- **Un impegno concreto nella riduzione dell'impatto ambientale:** scegliamo con attenzione i materiali e adottiamo processi produttivi avanzati e responsabili, per minimizzare l'impronta ecologica e promuovere un modello di sviluppo più rispettoso del pianeta.

# INDICE INDEX

	PAG.
<b>CAMINETTI ELETTRICI DA INCASSO</b> <i>RECESSED ELECTRIC FIREPLACES</i>	12-25
<b>CAMINETTI ELETTRICI DA PARETE</b> <i>WALL-MOUNTED ELECTRIC FIREPLACES</i>	26-33
<b>CAMINETTI ELETTRICI VAPORE ACQUEO</b> <i>ELECTRIC WATER VAPOUR FIREPLACES</i>	34-47
<b>CAMINETTI ELETTRICI OLOGRAFICI</b> <i>HOLOGRAPHIC ELECTRIC FIREPLACES</i>	48-55
<b>CAMINETTI ELETTRICI DA PAVIMENTO</b> <i>ELECTRIC FLOOR STANDING FIREPLACES</i>	56-65
<b>RISCALDATORI TERMOPELLET</b> <i>THERMOPELLET HEATERS</i>	66-69
<b>TERMO ARREDI</b> <i>HEATING FURNITURE</i>	70-75
<b>RISCALDATORI INFRAROSSI</b> <i>INFRARED HEATING LAMPS</i>	76-105
<b>MOBILI CON CAMINETTI ELETTRICI</b> <i>FURNITURE WITH ELECTRIC FIREPLACES</i>	106-107
<b>PARETI ATTREZZATE CINEWALL</b> <i>CUSTOMIZED CINEWALL</i>	108-109
<b>CONDIZIONI DI FORNITURA</b> <i>SUPPLY CONDITIONS</i>	110-111



# CAMINETTI ELETTRICI

SINED progetta e produce da molti anni caminetti elettrici per ambienti interni ed esterni, con un'attenzione particolare al mondo del benessere e del wellness.

Le nostre soluzioni uniscono funzionalità ed estetica, creando atmosfere accoglienti e rilassanti, perfettamente in linea con l'esigenza di armonia tra comfort e sostenibilità.

Che si tratti di spazi domestici, aree spa o ambienti outdoor, i nostri caminetti sono pensati per offrire esperienze sensoriali uniche, nel pieno rispetto dell'ambiente.

I nostri caminetti, da appoggio o da incasso a parete o in mobili, sono progettati non solo per riscaldare, ma anche per arredare con stile e creare atmosfera in ogni tipo di ambiente.

Grazie al loro design curato e alla versatilità d'installazione, si adattano perfettamente a spazi interni ed esterni, contribuendo a trasformare ogni contesto in un luogo accogliente e ricco di charme — in particolare nelle aree wellness, dove l'estetica e la sensazione di benessere sono elementi fondamentali.

**Grazie alla collaborazione con importanti falegnamerie di alto design**, siamo in grado di offrire **mobili d'arredo su misura**, realizzabili in **diverse dimensioni, finiture e colori**, per adattarsi perfettamente a ogni stile e ambiente.

Queste partnership ci permettono di unire **tecnologia, estetica e artigianalità italiana**, creando soluzioni personalizzate che valorizzano ogni spazio con eleganza e funzionalità.



# ELECTRIC FIREPLACES

For many years, SINED has been designing and producing fireplaces for both indoor and outdoor spaces, with particular attention to the world of well-being and wellness.

Our solutions combine functionality and aesthetics, creating warm and relaxing atmospheres that perfectly reflect the need for harmony between comfort and sustainability.

Whether for private homes, spa areas, or outdoor settings, our fireplaces are designed to offer unique sensory experiences, always with full respect for the environment.

Our freestanding or built-in fireplaces, whether wall-mounted or integrated into custom furniture, are conceived not just to heat, but to furnish with style and to set the mood in any type of space.

Thanks to their refined design and versatile installation, they fit seamlessly into both indoor and outdoor environments, helping transform any context into a welcoming and charming place — especially in wellness areas, where aesthetics and a sense of well-being are essential elements.

**Through collaborations with leading high-end carpentries**, we offer **custom-made furniture**, available in a variety of sizes, finishes, and colors, to perfectly match any style or setting.

These partnerships allow us to merge **technology, design, and Italian craftsmanship**, creating tailor-made solutions that enhance each space with elegance and functionality.



# CAMINETTI ELETTRICI DA INCASSO O DA APPOGGIO ELECTRIC FIREPLACES, BUILT-IN OR FREESTANDING

SINED ha sviluppato una **linea di caminetti elettrici a LED da incasso** pensata per integrarsi con eleganza in **ambienti moderni, classici o contract**.

Questi prodotti si distinguono per:

- **Realismo della fiamma LED:** giochi di luce sofisticati che simulano la fiamma in modo naturale.
- **Installazione versatile:** ideali per incasso in **pareti in cartongesso, mobili su misura, contropareti decorative o arredi modulari**.
- **Cornici e finiture minimali:** per lasciare il massimo spazio alla fiamma e armonizzarsi con ogni stile.

#### Vantaggi esclusivi dei caminetti SINED

- **Telecomando e controllo digitale**
- **Funzione riscaldamento opzionale**, indipendente dalla fiamma
- **Consumo energetico ridotto**, ideale anche per uso decorativo continuativo
- Disponibili in **diverse dimensioni e potenze**
- Compatibili con **arredi personalizzati** o integrabili in progetti o pareti attrezzate su misura

Sined ha studiato diverse misure ideali per vari ambienti e diverse utilizzi:

- 60 cm pensato per essere incasso in conici in legno
- 75 cm studiato per entrate perfettamente nei camini di vecchi case d'epoca
- 108 cm e 150 cm ideale per mobili parete attrezzare in base alla grandezza della stanza
- 180 cm studiati per essere inseriti in muri sotto tv
- 200 cm /300 cm importanti misure per hall e ristoranti

SINED has developed a line of recessed LED electric fireplaces designed to integrate elegantly into modern, classic or contract settings.

These products are distinguished by:

- **Realism of the LED flame:** sophisticated light effects that simulate the flame in a natural way.
- **Versatile installation:** ideal for recessed installation in plasterboard walls, custom-made furniture, decorative counter walls or modular furniture.
- **Minimal frames and finishes:** to leave maximum space for the flame and harmonise with any style.

#### Exclusive advantages of SINED fireplaces

- **Remote control and digital control**
- **Optional heating function**, independent of the flame
- **Low energy consumption**, also ideal for continuous decorative use
- Available in **different sizes and powers**
- Compatible with **customised furniture** or can be integrated into customised projects

Sined has designed different sizes ideal for various rooms and different uses

- 60 cm designed to be recessed into wooden cones
- 75 cm designed to fit perfectly into fireplaces in old houses
- 108 cm and 150 cm ideal for wall-mounted furniture depending on the size of the room
- 180 cm designed to be inserted in walls under TVs
- 200 cm /300 cm important measurements for halls and restaurants

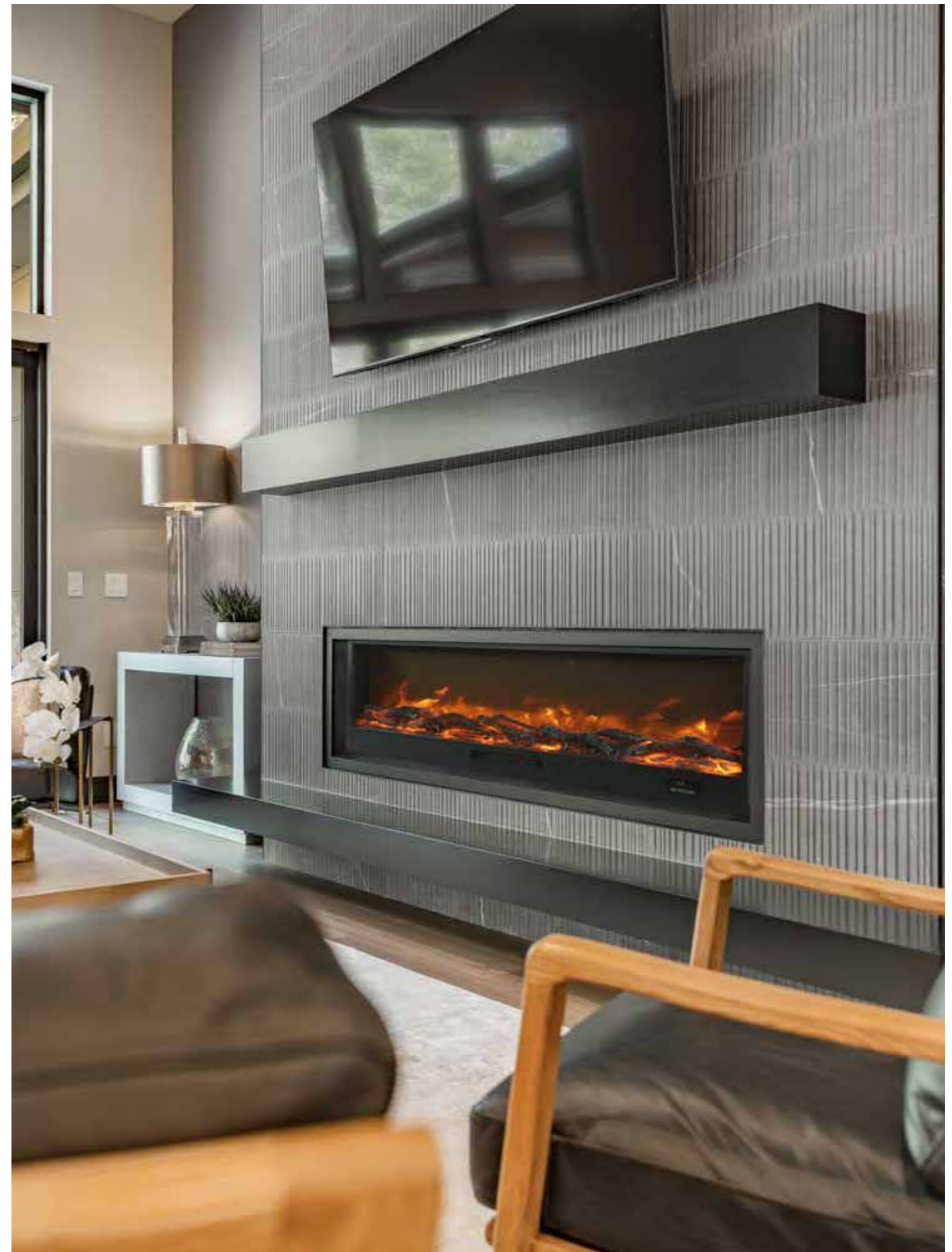

# CAMINETTO-VULCANO

8025431019263

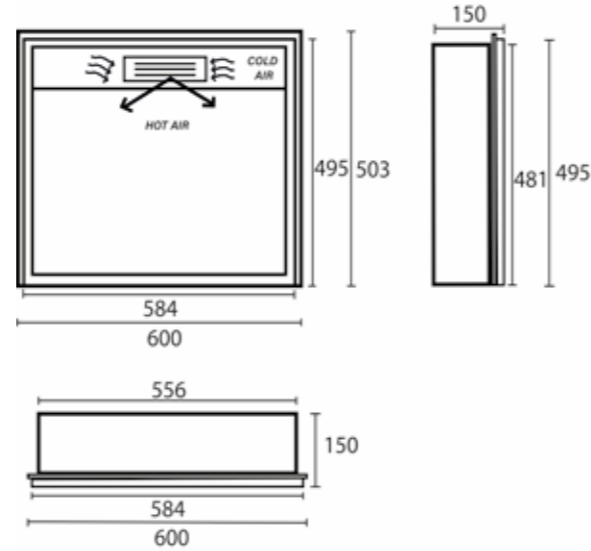

## CARATTERISTICHE/FEATURES

- **CAMINETTO ELETTRICO DA INCASSO / BUILT-IN ELECTRIC FIREPLACE**
- **MATERIALE: ACCIAIO/ MATERIAL: STEEL**
- **DIMENSIONI/DIMENSIONS 49,5X60X15 CM**
- **PESO/WEIGHT 10 KG**
- **POTENZA RISCALDAMENTO / HEATING POWER 750-1500 W**
- **TERMOMETRO E TERMOSTATO CON PROGRAMMAZIONE SETTIMANALE**  
*THERMOMETER AND THERMOSTAT WITH WEEKLY PROGRAMMING*
- **EFFETTO FIAMMA LED ULTRA REALISTICO CON 6 LIVELLI DI INTENSITÀ**  
*ULTRA-REALISTIC LED FLAME EFFECT WITH 6 INTENSITY LEVELS*
- **FUNZIONAMENTO SICURO SENZA COMBUSTIONE, FUMO O CENERI**  
*SAFE OPERATION WITHOUT COMBUSTION, SMOKE OR ASH*
- **EFFETTO SONORO CREPITIO LEGNA**  
*SOUND EFFECT OF CRACKLING WOOD*
- **ENTRATA ARIA E USCITA ARIA CALDA FRONTALE IN ALTO SOPRA LA FIAMMA**  
*AIR INLET AND HOT AIR OUTLET AT THE TOP FRONT ABOVE THE FLAME*
- **DOPPIA MODALITÀ DI FUNZIONAMENTO: SOLO EFFETTO FIAMMA O RISCALDAMENTO CON TERMOVENTILATORE PCT DA 1500 W ERMETICAMENTE SIGILLATO**  
*DUAL OPERATING MODE: FLAME EFFECT ONLY OR HEATING WITH HERMETICALLY SEALED 1500 W PCT MOTOR*
- **CONTROLLO TOTALE TRAMITE TELECOMANDO O APP TUYA**  
*FULL CONTROL VIA REMOTE CONTROL OR APP TUYA*



**UNICI MODELLI IN EUROPA CERTIFICATI E TESTATI PER INCASSO COMPLETO**

**THE ONLY MODELS IN EUROPE CERTIFIED AND TESTED FOR FULL FLUSH MOUNTING**



60 CM



EU directives compliance  
LVD 2014/35/UE EMC 2014/30/UE  
DERP 2009/125/CE  
RoHS 2011/65/EU ((UE) 2015/863)

# CAMINETTO-PANAREA

75 CM

8025431019270

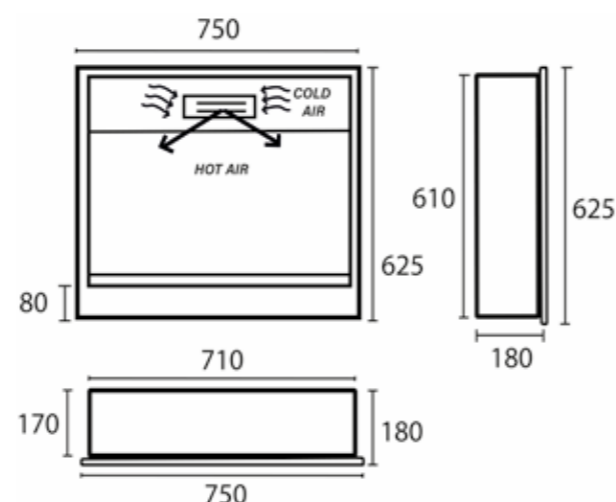

## CARATTERISTICHE/FEATURES

- **CAMINETTO ELETTRICO DA INCASSO / BUILT-IN ELECTRIC FIREPLACE**
- **MATERIALE: ACCIAIO / MATERIAL: STEEL**
- **DIMENSIONI / DIMENSIONS 75X62,5X18 CM**
- **PESO / WEIGHT 19,7 KG**
- **POTENZA RISCALDAMENTO / HEATING POWER 750-1500 W**
- **TERMOMETRO E TERMOSTATO CON PROGRAMMAZIONE SETTIMANALE**  
*THERMOMETER AND THERMOSTAT WITH WEEKLY PROGRAMMING*
- **EFFETTO FIAMMA LED ULTRA REALISTICO CON 6 LIVELLI DI INTENSITÀ**  
*ULTRA-REALISTIC LED FLAME EFFECT WITH 6 INTENSITY LEVELS*
- **EFFETTO SONORO CREPITIO LEGNA**  
*SOUND EFFECT OF CRACKLING WOOD*
- **FUNZIONAMENTO SICURO SENZA COMBUSTIONE, FUMO O CENERI**  
*SAFE OPERATION WITHOUT COMBUSTION, SMOKE OR ASH*
- **ENTRATA ARIA E USCITA ARIA CALDA FRONTALE IN ALTO SOPRA LA FIAMMA**  
*AIR INLET AND HOT AIR OUTLET AT THE TOP FRONT ABOVE THE FLAME*
- **DOPPIA MODALITÀ DI FUNZIONAMENTO: SOLO EFFETTO FIAMMA O RISCALDAMENTO CON TERMOVENTILATORE PCT DA 1500 W ERMETICAMENTE SIGILLATO**  
*DUAL OPERATING MODE: FLAME EFFECT ONLY OR HEATING WITH HERMETICALLY SEALED 1500 W PCT MOTOR*
- **CONTROLLO TOTALE TRAMITE TELECOMANDO O APP TUYA**  
*FULL CONTROL VIA REMOTE CONTROL OR APP TUYA*

**UNICI MODELLI IN EUROPA CERTIFICATI E TESTATI PER INCASSO COMPLETO**

**THE ONLY MODELS IN EUROPE CERTIFIED AND TESTED FOR FULL FLUSH MOUNTING**



EU directives compliance  
LVD 2014/35/UE EMC 2014/30/UE  
DERP 2009/125/CE  
RoHS 2011/65/EU ((UE) 2015/863)

# CAMINETTO-ISPICA-108

8025431151079

108 CM

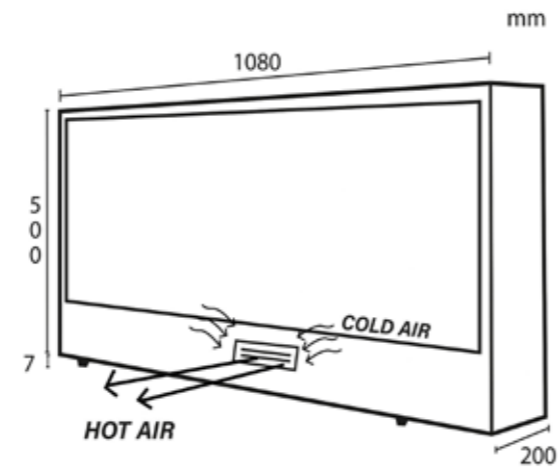

## CARATTERISTICHE/FEATURES

- **CAMINETTO ELETTRICO DA INCASSO O DA APPOGGIO / BUILT-IN RECESSED ELECTRIC FIREPLACE**
- **MATERIALE: ACCIAIO / MATERIAL: STEEL**
- **DIMENSIONI / DIMENSIONS 108X20X50 CM**
- **PESO / WEIGHT 30 KG**
- **POTENZA RISCALDAMENTO / HEATING POWER 750-1500 W**
- **INSTALLAZIONE VERSATILE: INCASSO A PARETE O INDIPENDENTE DA APPOGGIO**  
*VERSATILE INSTALLATION: WALL-MOUNTED OR FREESTANDING*
- **TERMOMETRO E TERMOSTATO CON PROGRAMMAZIONE SETTIMANALE**  
*THERMOMETER AND THERMOSTAT WITH WEEKLY PROGRAMMING*
- **EFFETTO FIAMMA LED ULTRA REALISTICO CON 6 LIVELLI DI INTENSITÀ**  
*ULTRA-REALISTIC LED FLAME EFFECT WITH 6 INTENSITY LEVELS*
- **CONTROLLO TOTALE TRAMITE TELECOMANDO O APP TUYA**   
*FULL CONTROL VIA REMOTE CONTROL OR APP TUYA*
- **EFFETTO SONORO CREPITIO LEGNA**  
*SOUND EFFECT OF CRACKLING WOOD*
- **ENTRATA ARIA E USCITA ARIA CALDA FRONTALE IN BASSO SOTTO LA FIAMMA**  
*AIR INLET AND HOT AIR OUTLET AT THE FRONT BELOW THE FLAME*
- **FUNZIONAMENTO SICURO SENZA COMBUSTIONE, FUMO O CENERI**  
*SAFE OPERATION WITHOUT COMBUSTION, SMOKE OR ASH*
- **DOPPIA MODALITÀ DI FUNZIONAMENTO: SOLO EFFETTO FIAMMA O RISCALDAMENTO CON TERMOVENTILATORE PCT DA 1500 W ERMETICAMENTE SIGILLATO**  
*DUAL OPERATING MODE: FLAME EFFECT ONLY OR HEATING WITH HERMETICALLY SEALED 1500 W PCT MOTOR*

**UNICI MODELLI IN EUROPA CERTIFICATI E TESTATI PER INCASSO COMPLETO**

**THE ONLY MODELS IN EUROPE CERTIFIED AND TESTED FOR FULL FLUSH MOUNTING**



EU directives compliance  
LVD 2014/35/UE EMC 2014/30/UE  
DERP 2009/125/CE  
RoHS 2011/65/EU ((UE) 2015/863)

# CAMINETTO-VULTURE-150

8025431016897

150 CM

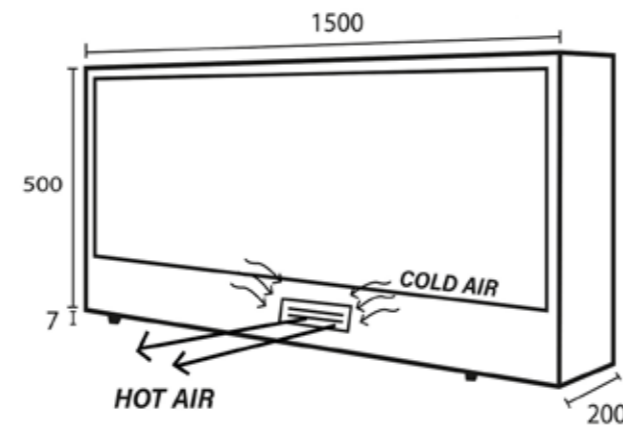

## CARATTERISTICHE/FEATURES

- **CAMINETTO ELETTRICO DA INCASSO O DA APPOGGIO / BUILT-IN RECESSED ELECTRIC FIREPLACE**
- **MATERIALE: ACCIAIO / MATERIAL: STEEL**
- **DIMENSIONI / DIMENSIONS 50,7X20X150 CM**
- **PESO / WEIGHT 30 KG**
- **POTENZA RISCALDAMENTO / HEATING POWER 750-1500 W**
- **INSTALLAZIONE VERSATILE: INCASSO A PARETE O INDIPENDENTE DA APPOGGIO**  
*VERSATILE INSTALLATION: WALL-MOUNTED OR FREESTANDING*
- **TERMOMETRO E TERMOSTATO CON PROGRAMMAZIONE SETTIMANALE**  
*THERMOMETER AND THERMOSTAT WITH WEEKLY PROGRAMMING*
- **EFFETTO FIAMMA LED ULTRA REALISTICO CON 6 LIVELLI DI INTENSITÀ**  
*ULTRA-REALISTIC LED FLAME EFFECT WITH 6 INTENSITY LEVELS*
- **CONTROLLO TOTALE TRAMITE TELECOMANDO O APP TUYA**   
*FULL CONTROL VIA REMOTE CONTROL OR APP TUYA*
- **EFFETTO SONORO CREPITIO LEGNA**  
*SOUND EFFECT OF CRACKLING WOOD*
- **ENTRATA ARIA E USCITA ARIA CALDA FRONTALE IN BASSO SOTTO LA FIAMMA**  
*AIR INLET AND HOT AIR OUTLET AT THE FRONT BELOW THE FLAME*
- **FUNZIONAMENTO SICURO SENZA COMBUSTIONE, FUMO O CENERI**  
*SAFE OPERATION WITHOUT COMBUSTION, SMOKE OR ASH*
- **DOPPIA MODALITÀ DI FUNZIONAMENTO: SOLO EFFETTO FIAMMA O RISCALDAMENTO CON TERMOVENTILATORE PCT DA 1500 W ERMETICAMENTE SIGILLATO**  
*DUAL OPERATING MODE: FLAME EFFECT ONLY OR HEATING WITH HERMETICALLY SEALED 1500 W PCT MOTOR*

**UNICI MODELLI IN EUROPA CERTIFICATI E TESTATI PER INCASSO COMPLETO**

**THE ONLY MODELS IN EUROPE CERTIFIED AND TESTED FOR FULL FLUSH MOUNTING**



EU directives compliance  
LVD 2014/35/UE EMC 2014/30/UE  
DERP 2009/125/CE  
RoHS 2011/65/EU ((UE) 2015/863)

# CAMINETTO-AMIATA-180

8025431016859

180 CM

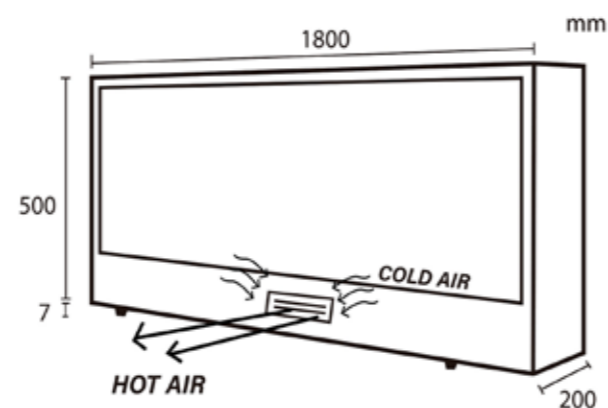

## CARATTERISTICHE/FEATURES

- **CAMINETTO ELETTRICO DA INCASSO O DA APPOGGIO / BUILT-IN RECESSED ELECTRIC FIREPLACE**
- **MATERIALE: ACCIAIO / MATERIAL: STEEL**
- **DIMENSIONI / DIMENSIONS 50,7X20X180 CM**
- **PESO / WEIGHT 36 KG**
- **POTENZA RISCALDAMENTO / HEATING POWER 750-1500 W**
- **INSTALLAZIONE VERSATILE: INCASSO A PARETE O INDIPENDENTE DA APPOGGIO**  
*VERSATILE INSTALLATION: WALL-MOUNTED OR FREESTANDING*
- **TERMOMETRO E TERMOSTATO CON PROGRAMMAZIONE SETTIMANALE**  
*THERMOMETER AND THERMOSTAT WITH WEEKLY PROGRAMMING*
- **EFFETTO FIAMMA LED ULTRA REALISTICO CON 6 LIVELLI DI INTENSITÀ**  
*ULTRA-REALISTIC LED FLAME EFFECT WITH 6 INTENSITY LEVELS*
- **CONTROLLO TOTALE TRAMITE TELECOMANDO O APP TUYA**   
*FULL CONTROL VIA REMOTE CONTROL OR APP TUYA*
- **EFFETTO SONORO CREPITIO LEGNA**  
*SOUND EFFECT OF CRACKLING WOOD*
- **ENTRATA ARIA E USCITA ARIA CALDA FRONTALE IN BASSO SOTTO LA FIAMMA**  
*AIR INLET AND HOT AIR OUTLET AT THE FRONT BELOW THE FLAME*
- **FUNZIONAMENTO SICURO SENZA COMBUSTIONE, FUMO O CENERI**  
*SAFE OPERATION WITHOUT COMBUSTION, SMOKE OR ASH*
- **DOPPIA MODALITÀ DI FUNZIONAMENTO: SOLO EFFETTO FIAMMA O RISCALDAMENTO CON TERMOVENTILATORE PCT DA 1500 W ERMETICAMENTE SIGILLATO**  
*DUAL OPERATING MODE: FLAME EFFECT ONLY OR HEATING WITH HERMETICALLY SEALED 1500 W PCT MOTOR*

**UNICI MODELLI IN EUROPA CERTIFICATI E TESTATI PER INCASSO COMPLETO**

**THE ONLY MODELS IN EUROPE CERTIFIED AND TESTED FOR FULL FLUSH MOUNTING**



EU directives compliance  
LVD 2014/35/UE EMC 2014/30/UE  
DERP 2009/125/CE  
RoHS 2011/65/EU ((UE) 2015/863)

# CAMINETTO-VESUVIO-200

8025431016880

200 CM

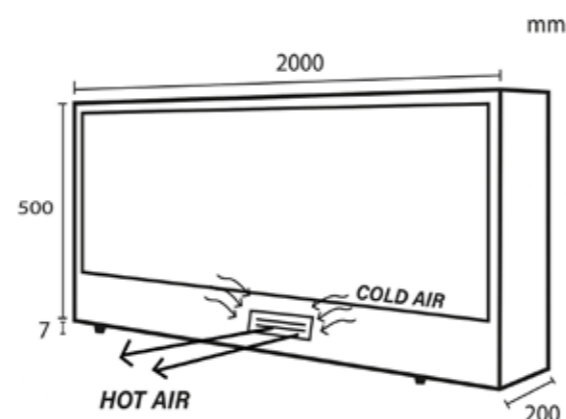

## CARATTERISTICHE/FEATURES

- **CAMINETTO ELETTRICO DA INCASSO O DA APPOGGIO / BUILT-IN RECESSED ELECTRIC FIREPLACE**
- **MATERIALE: ACCIAIO/ MATERIAL: STEEL**
- **DIMENSIONI/DIMENSIONS 50,7X20X200 CM**
- **PESO/WEIGHT 42 KG**
- **POTENZA RISCALDAMENTO / HEATING POWER 750-1500 W**
- **INSTALLAZIONE VERSATILE: INCASSO A PARETE O INDIPENDENTE DA APPOGGIO  
VERSATILE INSTALLATION: WALL-MOUNTED OR FREESTANDING**
- **TERMOMETRO E TERMOSTATO CON PROGRAMMAZIONE SETTIMANALE  
THERMOMETER AND THERMOSTAT WITH WEEKLY PROGRAMMING**
- **EFFETTO FIAMMA LED ULTRA REALISTICO CON 6 LIVELLI DI INTENSITÀ  
ULTRA-REALISTIC LED FLAME EFFECT WITH 6 INTENSITY LEVELS**
- **CONTROLLO TOTALE TRAMITE TELECOMANDO O APP TUYA **  
FULL CONTROL VIA REMOTE CONTROL OR APP TUYA
- **EFFETTO SONORO CREPITIO LEGNA  
SOUND EFFECT OF CRACKLING WOOD**
- **ENTRATA ARIA E USCITA ARIA CALDA FRONTALE IN BASSO SOTTO LA FIAMMA  
AIR INLET AND HOT AIR OUTLET AT THE FRONT BELOW THE FLAME**
- **FUNZIONAMENTO SICURO SENZA COMBUSTIONE, FUMO O CENERI  
SAFE OPERATION WITHOUT COMBUSTION, SMOKE OR ASH**
- **DOPPIA MODALITÀ DI FUNZIONAMENTO: SOLO EFFETTO FIAMMA O RISCALDAMENTO CON  
TERMOVENTILATORE PCT DA 1500 W ERMETICAMENTE SIGILLATO  
DUAL OPERATING MODE: FLAME EFFECT ONLY OR HEATING WITH HERMETICALLY SEALED 1500 W  
PCT MOTOR**

**UNICI MODELLI IN EUROPA CERTIFICATI E  
TESTATI PER INCASSO COMPLETO**

**THE ONLY MODELS IN EUROPE CERTIFIED  
AND TESTED FOR FULL FLUSH MOUNTING**



EU directives compliance  
LVD 2014/35/UE EMC 2014/30/UE  
DERP 2009/125/CE  
RoHS 2011/65/EU ((UE) 2015/863)

# CAMINETTO-ETNA-300

8025431016866

300 CM

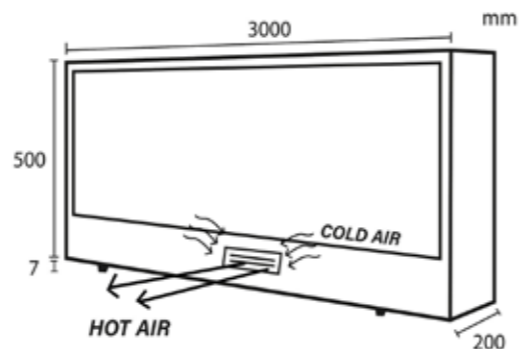

## CARATTERISTICHE/FEATURES

- **CAMINETTO ELETTRICO DA INCASSO O DA APPOGGIO / BUILT-IN RECESSED ELECTRIC FIREPLACE**
- **MATERIALE: ACCIAIO / MATERIAL: STEEL**
- **DIMENSIONI / DIMENSIONS 56X25X305 CM**
- **PESO / WEIGHT 63 KG**
- **POTENZA RISCALDAMENTO / HEATING POWER 750-1500 W**
- **INSTALLAZIONE VERSATILE: INCASSO A PARETE O INDIPENDENTE DA APPOGGIO**  
*VERSATILE INSTALLATION: WALL-MOUNTED OR FREESTANDING*
- **TERMOMETRO E TERMOSTATO CON PROGRAMMAZIONE SETTIMANALE**  
*THERMOMETER AND THERMOSTAT WITH WEEKLY PROGRAMMING*
- **EFFETTO FIAMMA LED ULTRA REALISTICO CON 6 LIVELLI DI INTENSITÀ**  
*ULTRA-REALISTIC LED FLAME EFFECT WITH 6 INTENSITY LEVELS*
- **CONTROLLO TOTALE TRAMITE TELECOMANDO**  
*FULL CONTROL VIA REMOTE CONTROL*
- **FUNZIONAMENTO SICURO SENZA COMBUSTIONE, FUMO O CENERI**  
*SAFE OPERATION WITHOUT COMBUSTION, SMOKE OR ASH*
- **ENTRATA ARIA E USCITA ARIA CALDA FRONTALE IN BASSO SOTTO LA FIAMMA**  
*AIR INLET AND HOT AIR OUTLET AT THE FRONT BELOW THE FLAME*
- **DOPPIA MODALITÀ DI FUNZIONAMENTO: SOLO EFFETTO FIAMMA O RISCALDAMENTO CON TERMOVENTILATORE PCT DA 1500 W ERMETICAMENTE SIGILLATO**  
*DUAL OPERATING MODE: FLAME EFFECT ONLY OR HEATING WITH HERMETICALLY SEALED 1500 W PCT MOTOR*

**UNICI MODELLI IN EUROPA CERTIFICATI E TESTATI PER INCASSO COMPLETO**

*THE ONLY MODELS IN EUROPE CERTIFIED AND TESTED FOR FULL FLUSH MOUNTING*



EU directives compliance  
LVD 2014/35/UE EMC 2014/30/UE  
DERP 2009/125/CE  
RoHS 2011/65/EU ((UE) 2015/863)

# CAMINETTI ELETTRICI DA PARETE

## Un camino come un quadro

I caminetti elettrici da parete proposti da SINED rappresentano la soluzione ideale per chi cerca:

- **Installazione facile e immediata:** si appendono alla parete come un quadro, senza necessità di opere murarie.
- **Effetto scenografico assicurato:** le fiamme LED donano calore visivo, creando un'atmosfera accogliente e moderna.
- **Spessore ridotto e design compatto,** ideale anche per piccoli ambienti o pareti di passaggio.

SINED non si limita a seguire il trend: lo anticipa.

A differenza di molte altre proposte sul mercato, offre:

- Una **gamma ampia di misure**, pensata per adattarsi a qualsiasi parete o esigenza di arredo.
- Design **minimal o decorativo**, con finiture in vetro, metallo o effetto pietra.
- **Sistemi di fissaggio sicuri e certificati**, pensati per installatori ma accessibili anche al cliente finale.

I Caminetti da parete SINED non hanno necessità di opere murarie.

Perfetti per appartamenti, uffici, hotel, ristoranti.

Flessibili: si possono spostare o reinstallare facilmente.

## Gamma dimensionale ampia: un prodotto per ogni spazio

Uno dei **principali punti di forza di SINED** è la varietà di modelli disponibili, in **diverse misure**:

- 98 cm per spazi contenuti o ambienti secondari.
- 128 cm per soggiorni e zone living.
- 152 cm per pareti scenografiche e progetti d'impatto.
- 183 cm per installazioni in contesti contract, hotel e showrooms.



# WALL-MOUNTED ELECTRIC FIREPLACES

## A fireplace like a painting

The electric wall-mounted fireplaces proposed by SINED represent the ideal solution for those looking for:

- **Easy and immediate installation:** they hang on the wall like a picture, with no need for masonry work.
- **Guaranteed scenic effect:** LED flames provide visual warmth, creating a cosy, modern atmosphere.
- **Reduced thickness and compact design,** also ideal for small rooms or passage walls.

SINED does not just follow the trend: it anticipates it.

Unlike many other proposals on the market, it offers:

- A **wide range of sizes**, designed to adapt to any wall or furnishing requirement.
- **Minimal or decorative design**, with glass, metal or stone effect finishes.
- **Safe and certified fixing systems**, designed for installers but also accessible to the end customer.

SINED wall-mounted fireplaces require no masonry work.

Perfect for flats, offices, hotels, restaurants.

Flexible: they can be moved or reinstalled easily.

## Wide dimensional range: a product for every space

One of **SINED's main strengths** is the variety of models available, in **different sizes**:

- 98 cm for small spaces or secondary rooms.
- 128 cm for living rooms and living areas.
- 152 cm for dramatic walls and impact projects.
- 183 cm for installations in contract settings, hotels and showrooms.



# CAMINETTO-PARETE-MONTE-BIANCO

98 CM

8025431019225

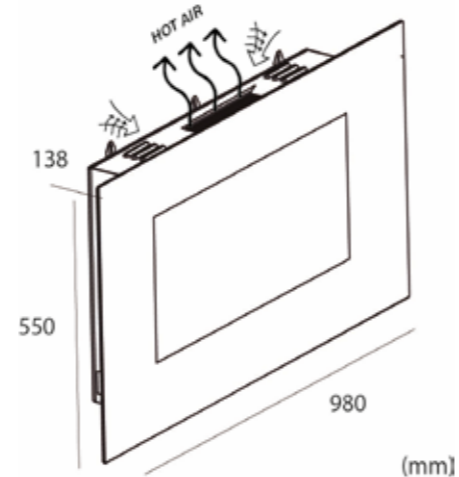

## CARATTERISTICHE/FEATURES

- **CAMINETTO ELETTRICO DA PARETE / ELECTRIC WALL-FIREPLACE**
- **MATERIALE: ACCIAIO/ MATERIAL: STEEL**
- **DIMENSIONI/DIMENSIONS 98X55X14 CM**
- **PESO/WEIGHT 15,6 KG**
- **POTENZA RISCALDAMENTO / ADJUSTABLE POWER 750-1500 W**
- **EFFETTO FIAMMA LED ULTRA REALISTICO CON 6 LIVELLI DI INTENSITÀ  
ULTRA-REALISTIC LED FLAME EFFECT WITH 6 INTENSITY LEVELS**
- **CONTROLLO TOTALE TRAMITE TELECOMANDO  
FULL CONTROL VIA REMOTE CONTROL**
- **FUNZIONAMENTO SICURO SENZA COMBUSTIONE, FUMO O CENERI  
SAFE OPERATION WITHOUT COMBUSTION, SMOKE OR ASH**
- **DOPPIA MODALITÀ DI FUNZIONAMENTO: SOLO EFFETTO FIAMMA O RISCALDAMENTO CON  
TERMOVENTILATORE PCT DA 1500 W ERMETICAMENTE SIGILLATO  
DUAL OPERATING MODE: FLAME EFFECT ONLY OR HEATING WITH HERMETICALLY SEALED 1500 W  
PCT MOTOR**

### ATTENZIONE! / ATTENTION!

**ENTRATA E USCITA ARIA CALDA SUPERIORE/ UPPER HOT AIR  
INLET AND OUTLET**

**INSTALLAZIONE SOLO APPESI ALLA PARETE, NON DEVONO  
ESSERE INSTALLATI/INCASSATI ALL'INTERNO  
WALL-MOUNTED INSTALLATION; MUST NOT BE  
INSTALLED/RECESSED INSIDE**

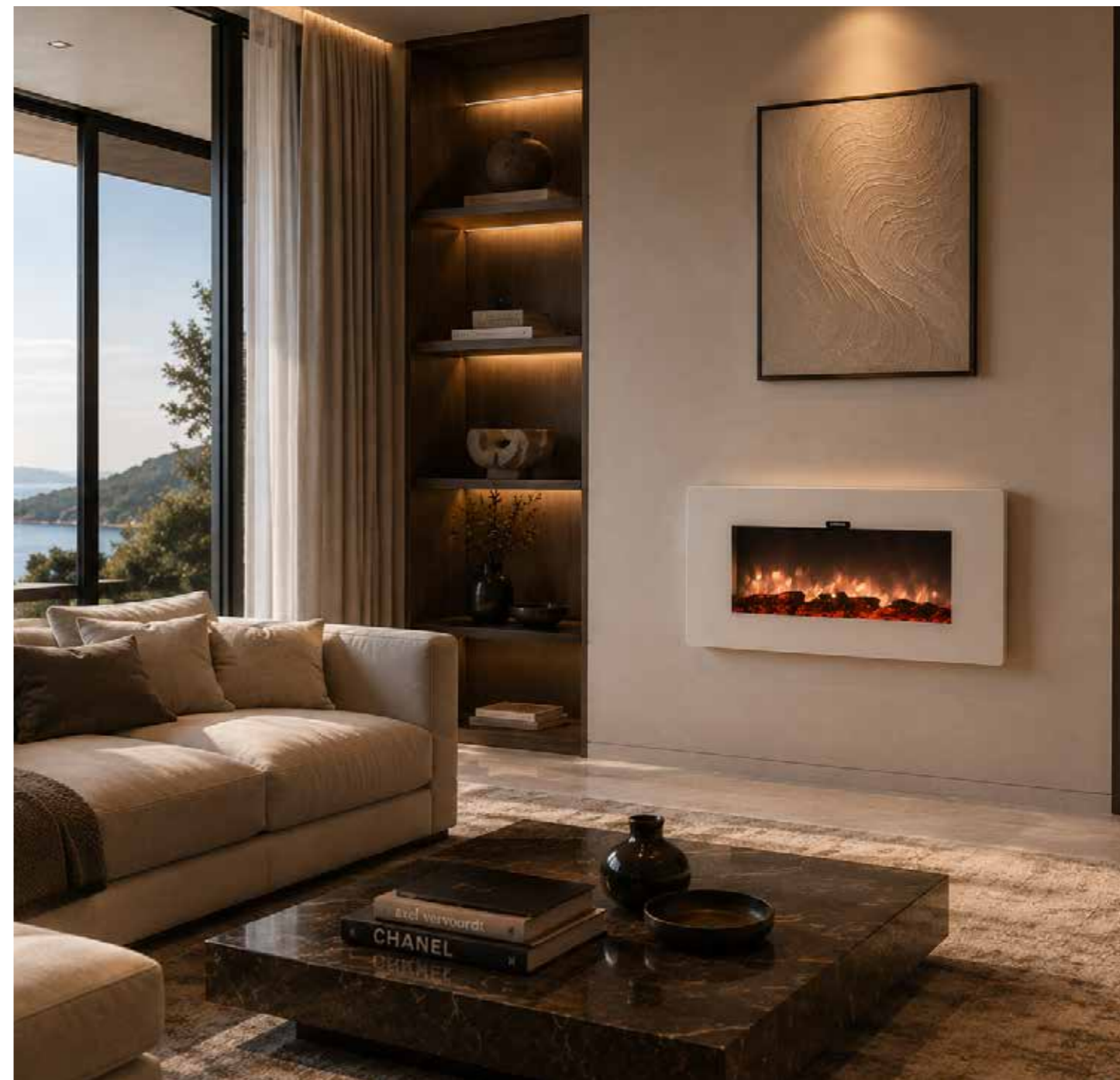

EU directives compliance  
LVD 2014/35/UE EMC 2014/30/UE  
DERP 2009/125/CE  
RoHS 2011/65/EU ((UE) 2015/863)

# CAMINETTO-PARETE-APRICA

152 CM

8025431019249

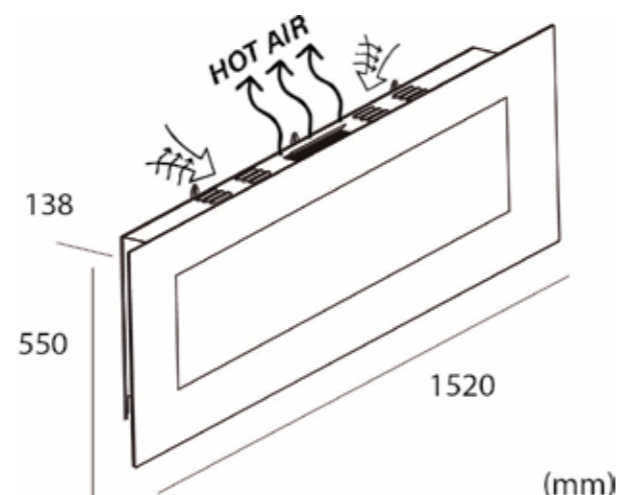

## CARATTERISTICHE/FEATURES

- CAMINETTO ELETTRICO DA PARETE / ELECTRIC WALL-FIREPLACE
- MATERIALE: ACCIAIO / MATERIAL: STEEL
- DIMENSIONI / DIMENSIONS 152X55X13,8 CM
- PESO / WEIGHT 24,1 KG
- POTENZA RISCALDAMENTO / ADJUSTABLE POWER 750-1500 W
- EFFETTO FIAMMA LED ULTRA REALISTICO CON 6 LIVELLI DI INTENSITÀ  
ULTRA-REALISTIC LED FLAME EFFECT WITH 6 INTENSITY LEVELS
- CONTROLLO TOTALE TRAMITE TELECOMANDO  
FULL CONTROL VIA REMOTE CONTROL
- FUNZIONAMENTO SICURO SENZA COMBUSTIONE, FUMO O CENERI  
SAFE OPERATION WITHOUT COMBUSTION, SMOKE OR ASH
- DOPPIA MODALITÀ DI FUNZIONAMENTO: SOLO EFFETTO FIAMMA O RISCALDAMENTO CON TERMOVENTILATORE PCT DA 1500 W ERMETICAMENTE SIGILLATO  
DUAL OPERATING MODE: FLAME EFFECT ONLY OR HEATING WITH HERMETICALLY SEALED 1500 W PCT MOTOR

### ATTENZIONE! / ATTENTION!

ENTRATA E USCITA ARIA CALDA SUPERIORE / UPPER HOT AIR INLET AND OUTLET

INSTALLAZIONE SOLO APPESI ALLA PARETE, NON DEVONO ESSERE INSTALLATI/INCASSATI ALL'INTERNO

WALL-MOUNTED INSTALLATION; MUST NOT BE INSTALLED/RECESSED INSIDE



EU directives compliance  
LVD 2014/35/UE EMC 2014/30/UE  
DERP 2009/125/CE  
RoHS 2011/65/EU ((UE) 2015/863)

# CAMINETTO-PARETE-PORDOI

8025431019256

183 CM

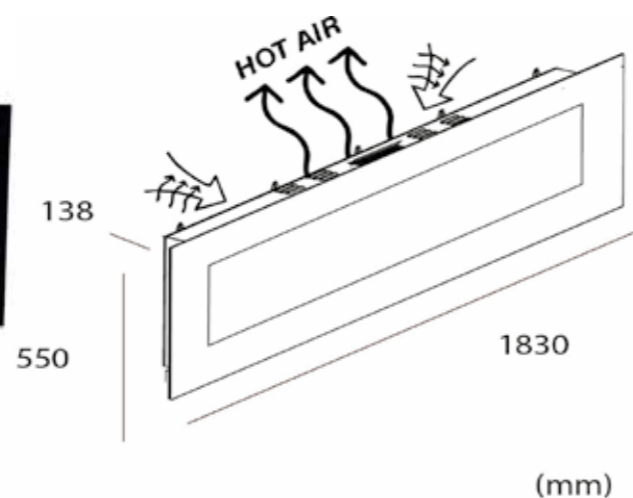

## CARATTERISTICHE/FEATURES

- **CAMINETTO ELETTRICO DA PARETE / ELECTRIC WALL-FIREPLACE**
- **MATERIALE: ACCIAIO/ MATERIAL: STEEL**
- **DIMENSIONI/DIMENSIONS 182,5X55X13,9 CM**
- **PESO/WEIGHT 29,5 KG**
- **POTENZA RISCALDAMENTO / ADJUSTABLE POWER 750-1500 W**
- **EFFETTO FIAMMA LED ULTRA REALISTICO CON 6 LIVELLI DI INTENSITÀ  
ULTRA-REALISTIC LED FLAME EFFECT WITH 6 INTENSITY LEVELS**
- **CONTROLLO TOTALE TRAMITE TELECOMANDO  
FULL CONTROL VIA REMOTE CONTROL**
- **FUNZIONAMENTO SICURO SENZA COMBUSTIONE, FUMO O CENERI  
SAFE OPERATION WITHOUT COMBUSTION, SMOKE OR ASH**
- **DOPPIA MODALITÀ DI FUNZIONAMENTO: SOLO EFFETTO FIAMMA O RISCALDAMENTO CON TERMOVENTILATORE PCT DA 1500 W ERMETICAMENTE SIGILLATO  
DUAL OPERATING MODE: FLAME EFFECT ONLY OR HEATING WITH HERMETICALLY SEALED 1500 W PCT MOTOR**

### ATTENZIONE! / ATTENTION!

**ENTRATA E USCITA ARIA CALDA SUPERIORE/ UPPER HOT AIR INLET AND OUTLET**

**INSTALLAZIONE SOLO APPESI ALLA PARETE, NON DEVONO ESSERE INSTALLATI/INCASSATI ALL'INTERNO**

**WALL-MOUNTED INSTALLATION; MUST NOT BE INSTALLED/RECESSED INSIDE**



EU directives compliance  
LVD 2014/35/UE EMC 2014/30/UE  
DERP 2009/125/CE  
RoHS 2011/65/EU ((UE) 2015/863)

# CAMINI ELETTRICI A VAPORE ACQUEO

## ELECTRIC WATER VAPOUR FIREPLACES

I caminetti elettrici a vapore acqueo SINED offrono un modo moderno e sicuro per godersi l'effetto visivo di un vero fuoco senza combustione né emissioni. Grazie alla combinazione di vapore acqueo e tecnologia LED, creano fiamme sorprendentemente realistiche che conferiscono calore ed eleganza a qualsiasi ambiente. Il loro funzionamento elettrico consente un'installazione semplice, senza scarico di fumi né manutenzione complessa, rendendoli una soluzione decorativa efficiente, pulita e versatile per interni contemporanei.

*SINED electric water vapour fireplaces offer a modern and safe way to enjoy the visual effect of a real fire without combustion or emissions. Thanks to the combination of water vapour and LED technology, they create surprisingly realistic flames that bring warmth and elegance to any space. Their electric operation allows for easy installation, without smoke outlets or complex maintenance, making them an efficient, clean and versatile decorative solution for contemporary interiors.*

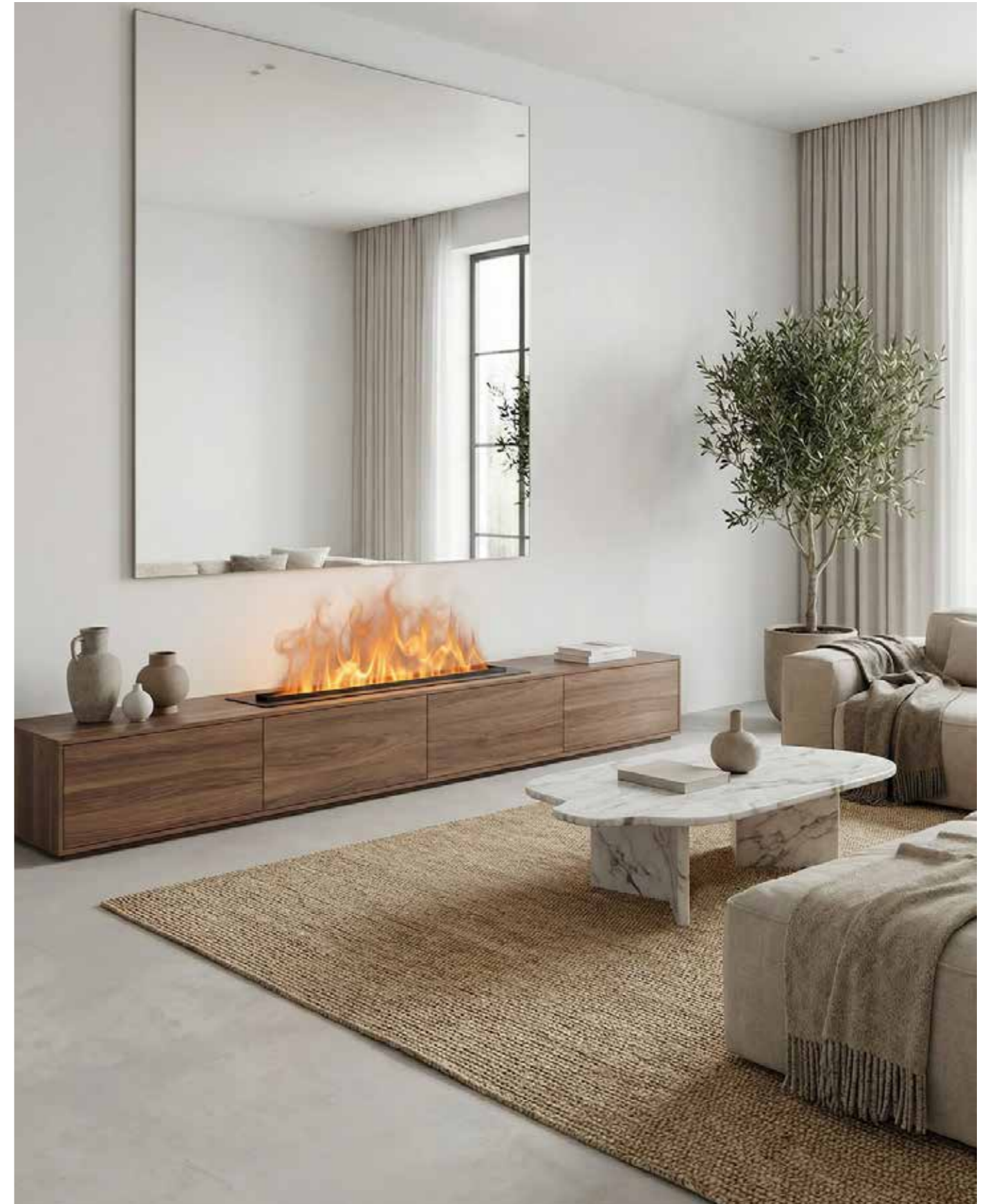

# CAMINETTO-CALDARO-50

8025431154896

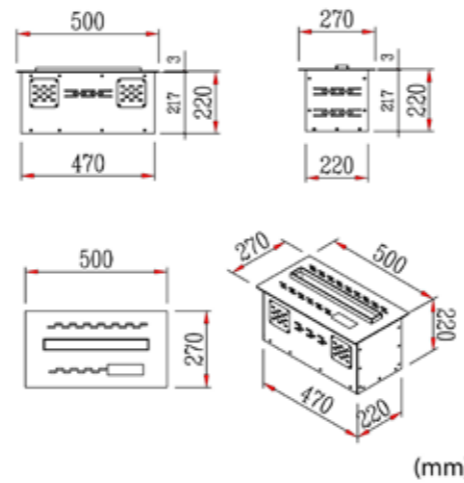

## CARATTERISTICHE/FEATURES

- **CAMINETTO ELETTRICO A NEBBIA DI VAPORE D'ACQUA / WATER MIST ELECTRIC FIREPLACE**
- **MATERIALE: ACCIAIO/ MATERIAL: STEEL**
- **DIMENSIONI/DIMENSIONS 50X27X23 CM**
- **PESO/WEIGHT 12,5 KG**
- **SERBATOIO DELL'ACQUA/WATER TANK 1,9L**
- **SOLO EFFETTO FIAMMA, NON GENERA CALORE REALE  
ONLY FLAME EFFECT, DOES NOT GENERATE ACTUAL HEAT**
- **BASSO CONSUMO POTENZA / LOW CONSUME POWER 57-160W**
- **CONSIGLIAMO DI UTILIZZARE ACQUA FILTRATA O ADDOLCITA  
WE RECOMMEND USING FILTERED OR SOFTENED WATER TO FILL IT**
- **FUNZIONAMENTO CONTINUO CON UNA CARICA DI ACQUA 7-8H  
RUNNING TIME WITH A WATER CHARGE OF 7-8 HOURS**
- **TRE LIVELLI DI REGOLAZIONE DELLA LUMINOSITÀ DELLA FIAMMA  
THREE LEVELS FLAME BRIGHTNESS**
- **4 LIVELLI DI ALTEZZA DELLA NEBBIA  
4 SPEED FOG ADJUSTMENT**
- **CONTROLLO TOTALE TRAMITE TELECOMANDO O PANNELLO DI CONTROLLO  
FULL CONTROL VIA REMOTE CONTROL OR CONTROL PANEL**
- **TECNOLOGIA A VAPORE ACQUEO (ULTRASONICA): EFFETTO FIAMMA TRIDIMENSIONALE  
ESTREMAMENTE REALISTICO, SENZA FUOCO REALE  
WATER VAPOUR TECHNOLOGY (ULTRASONIC): EXTREMELY REALISTIC THREE-DIMENSIONAL FLAME  
EFFECT, WITHOUT REAL FIRE**

50 CM

### EFFICIENZA ENERGETICA / ENERGY EFFICIENCY

**FUNZIONAMENTO ECOLOGICO: SENZA COMBUSTIONE, SENZA  
EMISSIONI, SENZA FUMO NÉ ODORI**

*ENVIRONMENTALLY FRIENDLY OPERATION: NO COMBUSTION, NO  
EMISSIONS, NO SMOKE OR ODOURS*



EU directives compliance  
LVD 2014/35/UE EMC 2014/30/UE  
DERP 2009/125/CE  
RoHS 2011/65/EU ((UE) 2015/863)

# CAMINETTO-ORTISEI-50

8025431159655



\*DISPONIBILE SOLO SU ORDINAZIONE  
\*AVAILABLE ONLY UPON REQUEST

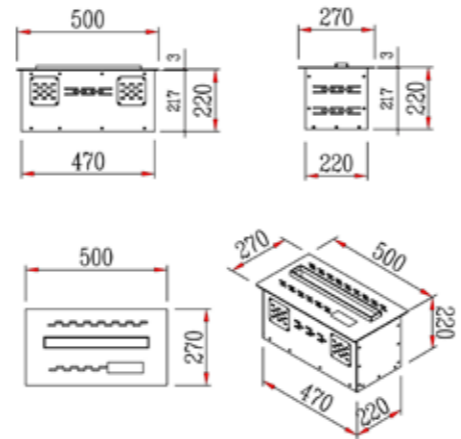

(mm)

## CARATTERISTICHE/FEATURES

- **CAMINETTO ELETTRICO A NEBBIA DI VAPORE D'ACQUA / WATER MIST ELECTRIC FIREPLACE**
- **MATERIALE: ACCIAIO/ MATERIAL: STEEL**
- **DIMENSIONI/DIMENSIONS 50X27X23CM**
- **PESO/WEIGHT 12,5 KG**
- **SERBATOIO DELL'ACQUA/WATER TANK 1,9L**
- **SOLO EFFETTO FIAMMA, NON GENERA CALORE REALE  
ONLY FLAME EFFECT, DOES NOT GENERATE ACTUAL HEAT**
- **BASSO CONSUMO POTENZA / LOW CONSUME POWER 57-160W**
- **CONSIGLIAMO DI UTILIZZARE ACQUA FILTRATA O ADDOLCITA  
WE RECOMMEND USING FILTERED OR SOFTENED WATER TO FILL IT**
- **FUNZIONAMENTO CONTINUO CON UNA CARICA DI ACQUA 7-8H  
RUNNING TIME WITH A WATER CHARGE OF 7-8 HOURS**
- **7 COLORI DELLE FIAMME CON EFFETTO CANGIANTE  
7 FLAME COLOURS CHANGING EFFECT**
- **EFFETTO SONORO CREPITIO LEGNA & EROGATORE ESSENZE  
SOUND EFFECT OF CRACKLING WOOD AND ESSENCE DISPENSER**
- **4 LIVELLI DI ALTEZZA DELLA NEBBIA  
4 SPEED FOG ADJUSTMENT**
- **CONTROLLO TOTALE TRAMITE TELECOMANDO O PANNELLO DI CONTROLLO  
FULL CONTROL VIA REMOTE CONTROL OR CONTROL PANEL**
- **TECNOLOGIA A VAPORE ACQUEO (ULTRASONICA): EFFETTO FIAMMA TRIDIMENSIONALE  
ESTREMAMENTE REALISTICO, SENZA FUOCO REALE  
WATER VAPOUR TECHNOLOGY (ULTRASONIC): EXTREMELY REALISTIC THREE-DIMENSIONAL FLAME  
EFFECT, WITHOUT REAL FIRE**

## 50 CM



### EFFICIENZA ENERGETICA / ENERGY EFFICIENCY

**FUNZIONAMENTO ECOLOGICO: SENZA COMBUSTIONE, SENZA  
EMISSIONI, SENZA FUMO NÉ ODORI**

*ENVIRONMENTALLY FRIENDLY OPERATION: NO COMBUSTION, NO  
EMISSIONS, NO SMOKE OR ODOURS*



EU directives compliance  
LVD 2014/35/UE EMC 2014/30/UE  
DERP 2009/125/CE  
RoHS 2011/65/EU ((UE) 2015/863)

# CAMINETTO-RESIA-100

8025431154902

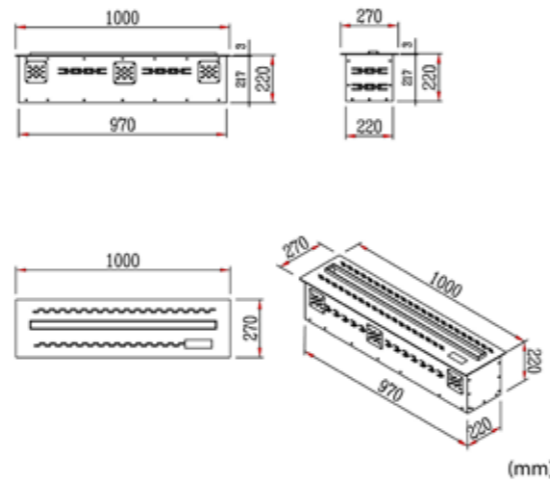

## CARATTERISTICHE/FEATURES

- CAMINETTO ELETTRICO A NEBBIA DI VAPORE D'ACQUA / WATER MIST ELECTRIC FIREPLACE
- MATERIALE: ACCIAIO/ MATERIAL: STEEL
- DIMENSIONI/DIMENSIONS 100X27X23 CM
- PESO/WEIGHT 25 KG
- SERBATOIO DELL'ACQUA/WATER TANK 5,1L
- SOLO EFFETTO FIAMMA, NON GENERA CALORE REALE  
ONLY FLAME EFFECT, DOES NOT GENERATE ACTUAL HEAT
- BASSO CONSUMO POTENZA / LOW CONSUME POWER 57-160W
- CONSIGLIAMO DI UTILIZZARE ACQUA FILTRATA O ADDOLCITA  
WE RECOMMEND USING FILTERED OR SOFTENED WATER TO FILL IT
- FUNZIONAMENTO CONTINUO CON UNA CARICA DI ACQUA 7-8H  
RUNNING TIME WITH A WATER CHARGE OF 7-8 HOURS
- TRE LIVELLI DI REGOLAZIONE DELLA LUMINOSITÀ DELLA FIAMMA  
THREE LEVELS FLAME BRIGHTNESS
- 4 LIVELLI DI ALTEZZA DELLA NEBBIA  
4 SPEED FOG ADJUSTMENT
- CONTROLLO TOTALE TRAMITE TELECOMANDO O PANNELLO DI CONTROLLO  
FULL CONTROL VIA REMOTE CONTROL OR CONTROL PANEL
- TECNOLOGIA A VAPORE ACQUEO (ULTRASONICA): EFFETTO FIAMMA TRIDIMENSIONALE  
ESTREMAMENTE REALISTICO, SENZA FUOCO REALE  
WATER VAPOUR TECHNOLOGY (ULTRASONIC): EXTREMELY REALISTIC THREE-DIMENSIONAL FLAME  
EFFECT, WITHOUT REAL FIRE

100 CM



### EFFICIENZA ENERGETICA / ENERGY EFFICIENCY

**FUNZIONAMENTO ECOLOGICO: SENZA COMBUSTIONE, SENZA EMISSIONI, SENZA FUMO NÉ ODORI**

ENVIRONMENTALLY FRIENDLY OPERATION: NO COMBUSTION, NO EMISSIONS, NO SMOKE OR ODOURS

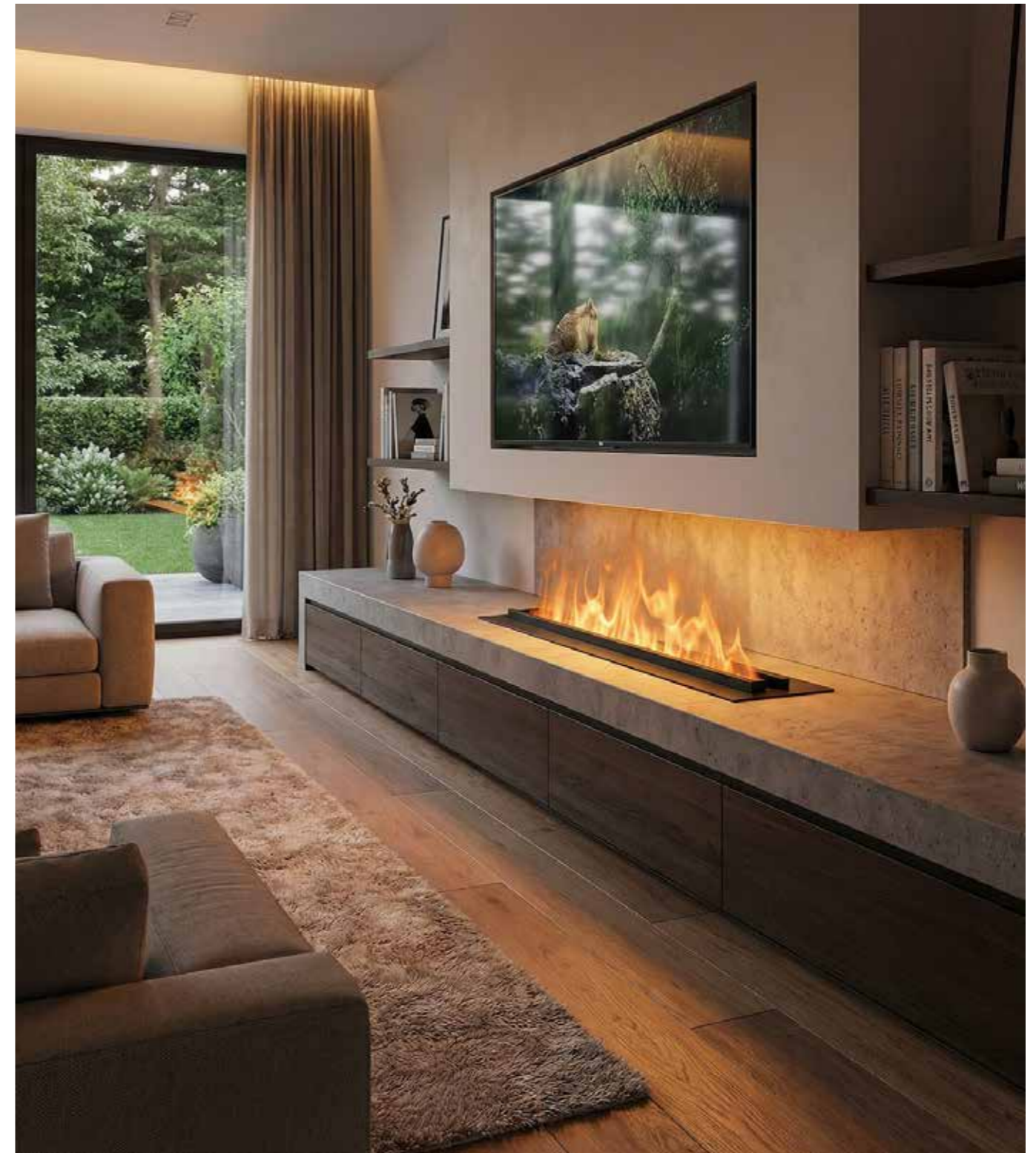

EU directives compliance  
LVD 2014/35/UE EMC 2014/30/UE  
DERP 2009/125/CE  
RoHS 2011/65/EU ((UE) 2015/863)

# CAMINETTO-CANAZEI-100

8025431159648



\*DISPONIBILE SOLO SU ORDINAZIONE  
\*AVAILABLE ONLY UPON REQUEST

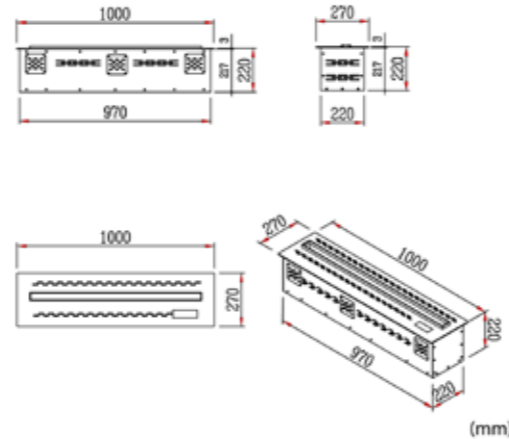

## CARATTERISTICHE/FEATURES

- **CAMINETTO ELETTRICO A NEBBIA DI VAPORE D'ACQUA / WATER MIST ELECTRIC FIREPLACE**
- **MATERIALE: ACCIAIO / MATERIAL: STEEL**
- **DIMENSIONI / DIMENSIONS 100X27X23 CM**
- **PESO / WEIGHT 25 KG**
- **SERBATOIO DELL'ACQUA / WATER TANK 5,1L**
- **SOLO EFFETTO FIAMMA, NON GENERA CALORE REALE  
ONLY FLAME EFFECT, DOES NOT GENERATE ACTUAL HEAT**
- **BASSO CONSUMO POTENZA / LOW CONSUME POWER 57-160W**
- **CONSIGLIAMO DI UTILIZZARE ACQUA FILTRATA O ADDOLCITA  
WE RECOMMEND USING FILTERED OR SOFTENED WATER TO FILL IT**
- **FUNZIONAMENTO CONTINUO CON UNA CARICA DI ACQUA 7-8H  
RUNNING TIME WITH A WATER CHARGE OF 7-8 HOURS**
- **7 COLORI DELLE FIAMME CON EFFETTO CANGIANTE  
7 FLAME COLOURS CHANGING EFFECT**
- **EFFETTO SONORO CREPITIO LEGNA & EROGATORE ESSENZE  
SOUND EFFECT OF CRACKLING WOOD AND ESSENCE DISPENSER**
- **4 LIVELLI DI ALTEZZA DELLA NEBBIA  
4 SPEED FOG ADJUSTMENT**
- **CONTROLLO TOTALE TRAMITE TELECOMANDO O PANNELLO DI CONTROLLO  
FULL CONTROL VIA REMOTE CONTROL OR CONTROL PANEL**
- **TECNOLOGIA A VAPORE ACQUEO (ULTRASONICA): EFFETTO FIAMMA TRIDIMENSIONALE  
ESTREMAMENTE REALISTICO, SENZA FUOCO REALE  
WATER VAPOUR TECHNOLOGY (ULTRASONIC): EXTREMELY REALISTIC THREE-DIMENSIONAL FLAME  
EFFECT, WITHOUT REAL FIRE**

100 CM

### EFFICIENZA ENERGETICA / ENERGY EFFICIENCY

**FUNZIONAMENTO ECOLOGICO: SENZA COMBUSTIONE, SENZA  
EMISSIONI, SENZA FUMO NÉ ODORI**

*ENVIRONMENTALLY FRIENDLY OPERATION: NO COMBUSTION, NO  
EMISSIONS, NO SMOKE OR ODOURS*



EU directives compliance  
LVD 2014/35/UE EMC 2014/30/UE  
DERP 2009/125/CE  
RoHS 2011/65/EU ((UE) 2015/863)

# CAMINETTO-EGA-150

8025431154919

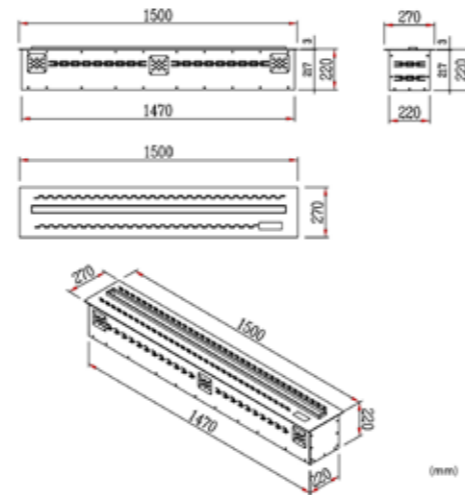

## CARATTERISTICHE/FEATURES

- **CAMINETTO ELETTRICO A NEBBIA DI VAPORE D'ACQUA / WATER MIST ELECTRIC FIREPLACE**
- **MATERIALE: ACCIAIO/ MATERIAL: STEEL**
- **DIMENSIONI/DIMENSIONS 150X27X23 CM**
- **PESO/WEIGHT 34,5 KG**
- **SERBATOIO DELL'ACQUA/WATER TANK 8,2L**
- **SOLO EFFETTO FIAMMA, NON GENERA CALORE REALE  
ONLY FLAME EFFECT, DOES NOT GENERATE ACTUAL HEAT**
- **BASSO CONSUMO POTENZA / LOW CONSUME POWER 57-160W**
- **CONSIGLIAMO DI UTILIZZARE ACQUA FILTRATA O ADDOLCITA  
WE RECOMMEND USING FILTERED OR SOFTENED WATER TO FILL IT**
- **FUNZIONAMENTO CONTINUO CON UNA CARICA DI ACQUA 7-8H  
RUNNING TIME WITH A WATER CHARGE OF 7-8 HOURS**
- **TRE LIVELLI DI REGOLAZIONE DELLA LUMINOSITÀ DELLA FIAMMA  
THREE LEVELS FLAME BRIGHTNESS**
- **4 LIVELLI DI ALTEZZA DELLA NEBBIA  
4 SPEED FOG ADJUSTMENT**
- **CONTROLLO TOTALE TRAMITE TELECOMANDO O PANNELLO DI CONTROLLO  
FULL CONTROL VIA REMOTE CONTROL OR CONTROL PANEL**
- **TECNOLOGIA A VAPORE ACQUEO (ULTRASONICA): EFFETTO FIAMMA TRIDIMENSIONALE  
ESTREMAMENTE REALISTICO, SENZA FUOCO REALE  
WATER VAPOUR TECHNOLOGY (ULTRASONIC): EXTREMELY REALISTIC THREE-DIMENSIONAL FLAME  
EFFECT, WITHOUT REAL FIRE**

150 CM

### EFFICIENZA ENERGETICA / ENERGY EFFICIENCY

**FUNZIONAMENTO ECOLOGICO: SENZA COMBUSTIONE, SENZA EMISSIONI, SENZA FUMO NÉ ODORI**

*ENVIRONMENTALLY FRIENDLY OPERATION: NO COMBUSTION, NO EMISSIONS, NO SMOKE OR ODOURS*



EU directives compliance  
LVD 2014/35/UE EMC 2014/30/UE  
DERP 2009/125/CE  
RoHS 2011/65/EU ((UE) 2015/863)

# CAMINETTO-EGNA-150

8025431159662



\*DISPONIBILE SOLO SU ORDINAZIONE  
\*AVAILABLE ONLY UPON REQUEST

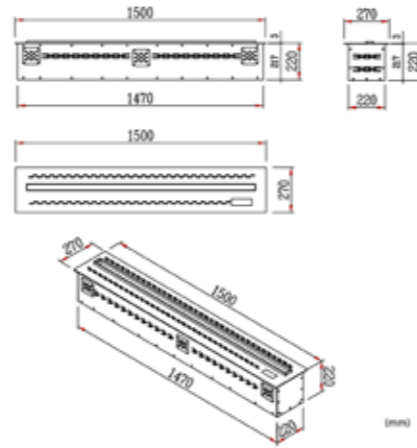

## CARATTERISTICHE/FEATURES

- **CAMINETTO ELETTRICO A NEBBIA DI VAPORE D'ACQUA / WATER MIST ELECTRIC FIREPLACE**
- **MATERIALE: ACCIAIO/ MATERIAL: STEEL**
- **DIMENSIONI/DIMENSIONS 150X27X23 CM**
- **PESO/WEIGHT 34,5 KG**
- **SERBATOIO DELL'ACQUA/WATER TANK 8,2 L**
- **SOLO EFFETTO FIAMMA, NON GENERA CALORE REALE  
ONLY FLAME EFFECT, DOES NOT GENERATE ACTUAL HEAT**
- **BASSO CONSUMO POTENZA / LOW CONSUME POWER 57-160W**
- **CONSIGLIAMO DI UTILIZZARE ACQUA FILTRATA O ADDOLCITA  
WE RECOMMEND USING FILTERED OR SOFTENED WATER TO FILL IT**
- **FUNZIONAMENTO CONTINUO CON UNA CARICA DI ACQUA 7-8H  
RUNNING TIME WITH A WATER CHARGE OF 7-8 HOURS**
- **7 COLORI DELLE FIAMME CON EFFETTO CANGIANTE  
7 FLAME COLOURS CHANGING EFFECT**
- **EFFETTO SONORO CREPITIO LEGNA & EROGATORE ESSENZE  
SOUND EFFECT OF CRACKLING WOOD AND ESSENCE DISPENSER**
- **4 LIVELLI DI ALTEZZA DELLA NEBBIA  
4 SPEED FOG ADJUSTMENT**
- **CONTROLLO TOTALE TRAMITE TELECOMANDO O PANNELLO DI CONTROLLO  
FULL CONTROL VIA REMOTE CONTROL OR CONTROL PANEL**
- **TECNOLOGIA A VAPORE ACQUEO (ULTRASONICA): EFFETTO FIAMMA TRIDIMENSIONALE  
ESTREMAMENTE REALISTICO, SENZA FUOCO REALE  
WATER VAPOUR TECHNOLOGY (ULTRASONIC): EXTREMELY REALISTIC THREE-DIMENSIONAL FLAME  
EFFECT, WITHOUT REAL FIRE**

150 CM

### EFFICIENZA ENERGETICA / ENERGY EFFICIENCY

**FUNZIONAMENTO ECOLOGICO: SENZA COMBUSTIONE, SENZA  
EMISSIONI, SENZA FUMO NÉ ODORI**

*ENVIRONMENTALLY FRIENDLY OPERATION: NO COMBUSTION, NO  
EMISSIONS, NO SMOKE OR ODOURS*

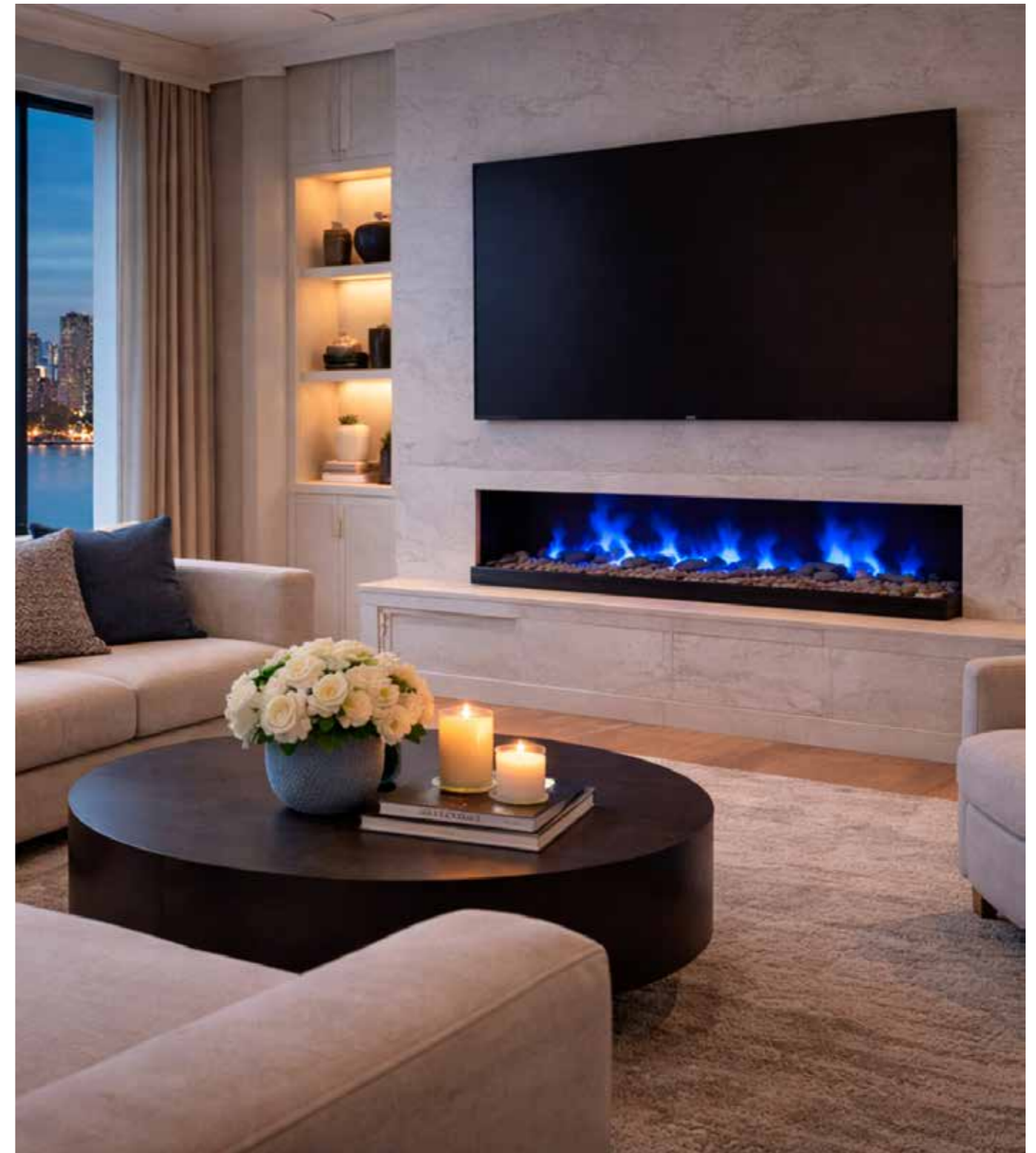

EU directives compliance  
LVD 2014/35/UE EMC 2014/30/UE  
DERP 2009/125/CE  
RoHS 2011/65/EU ((UE) 2015/863)

# CAMINETTI OLOGRAFICI HOLOGRAPHIC FIREPLACES

I camini olografici SINED rappresentano la massima espressione dell'innovazione nel mondo del fuoco decorativo. Grazie ad avanzate tecnologie di proiezione, ricreano un effetto fiamma tridimensionale estremamente realistico, con una profondità visiva sorprendente e un movimento naturale che trasforma qualsiasi spazio in un ambiente elegante e contemporaneo.

Funzionando esclusivamente con energia elettrica, questi caminetti non generano calore, fumo o residui, consentendo un'installazione pulita e sicura, ideale per progetti di interior design moderni, spazi commerciali o ambienti in cui il design è protagonista.

*SINED holographic fireplaces represent the ultimate expression of innovation in the world of decorative fireplaces. Thanks to advanced projection technologies, they recreate an extremely realistic three-dimensional flame effect, with surprising visual depth and natural movement that transforms any space into an elegant and contemporary environment.*

*Operating exclusively on electricity, these fireplaces generate no heat, smoke or waste, allowing for clean and safe installation, ideal for modern interior design projects, commercial spaces or environments where design takes centre stage. safety in a single solution.*



# CAMINETTO-TIRES-74

8025431158276

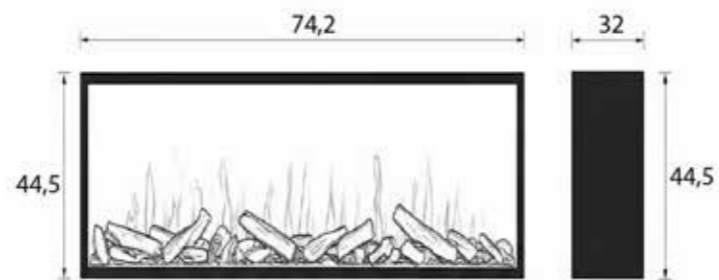

74 CM

## CARATTERISTICHE/FEATURES

- **CAMINETTO ELETTRICO DA INCASSO O DA APPOGGIO / BUILT-IN RECESSED ELECTRIC FIREPLACE**
- **MATERIALE: ACCIAIO / MATERIAL: STEEL**
- **DIMENSIONI / DIMENSIONS 32X74X44 CM**
- **PESO / WEIGHT 40 KG**
- **CONTROLLO TOTALE TRAMITE TELECOMANDO O PANNELLO DI CONTROLLO  
FULL CONTROL VIA REMOTE CONTROL OR CONTROL PANEL**
- **EFFETTO FIAMMA OLOGRAFICO E STEREOSCOPICO ULTRA REALISTICO  
ULTRA-REALISTIC HOLOGRAPHIC AND STEREOSCOPIC FLAME EFFECT**
- **CONSUMO ENERGETICO / ENERGY CONSUMPTION 10-50W**
- **EFFETTO SONORO CREPITIO LEGNA  
SOUND EFFECT OF CRACKLING WOOD**
- **TECNOLOGIA OLOGRAFICA 3D  
3D HOLOGRAPHIC TECHNOLOGY**
- **SOLO EFFETTO FIAMMA DECORATIVO NON RISCALDA  
DECORATIVE FLAME EFFECT ONLY, DOES NOT HEAT**



EU directives compliance  
LVD 2014/35/UE EMC 2014/30/UE  
DERP 2009/125/CE  
RoHS 2011/65/EU ((UE) 2015/863)

# CAMINETTO-LASA-125

8025431158283



\*DISPONIBILE SOLO SU ORDINAZIONE  
\*AVAILABLE ONLY UPON REQUEST

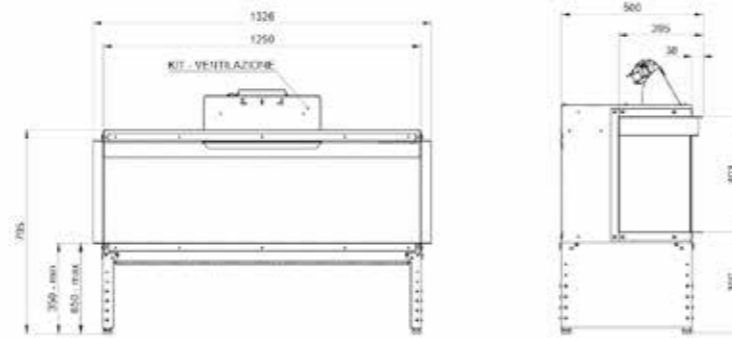

## 125 CM

### CARATTERISTICHE/FEATURES

- **CAMINETTO ELETTRICO DA INCASSO O DA APPOGGIO / BUILT-IN RECESSED ELECTRIC FIREPLACE**
- **MATERIALE: ACCIAIO / MATERIAL: STEEL**
- **DIMENSIONI / DIMENSIONS 1326X795X500 MM**
- **PESO / WEIGHT 55 KG**
- **PUOI SCEGLIERLO IN TRE DIVERSI MODELLI, A SECONDA DELLA CONFIGURAZIONE DEL VETRO / YOU CAN CHOOSE FROM THREE DIFFERENT MODELS, DEPENDING ON THE GLASS CONFIGURATION:**
  - LASA 125 CON VETRO PIATTO / WITH FLAT GLASS
  - LASA 125 EDGE CON VETRO ANGOLARE DESTRO O SINISTRO / EDGE WITH RIGHT- OR LEFT- ANGLED GLASS
  - LASA 125 VIEW CON VETRO TRIFACCIALE / VIEW WITH THREE-SIDED GLASS
- **EFFETTO FIAMMA OLOGRAFICO E STEREOSCOPICO ULTRA REALISTICO  
ULTRA-REALISTIC HOLOGRAPHIC AND STEREOSCOPIC FLAME EFFECT**
- **BASTA UNA PRESA DI CORRENTE PER INSTALLARLO / ALL YOU NEED IS A PLUG SOCKET TO INSTALL IT**
- **NON SCOTTA E NON FA SCINTILLE: I TUOI TAPPETI E I TUOI OGGETTI SARANNO AL SICURO  
IT DOESN'T GET HOT AND IT DOESN'T SPARK: YOUR RUGS AND YOUR BELONGINGS WILL BE SAFE**
- **POTENZA DI RISCALDAMENTO 2KW  
HEATING POWER 2KW**

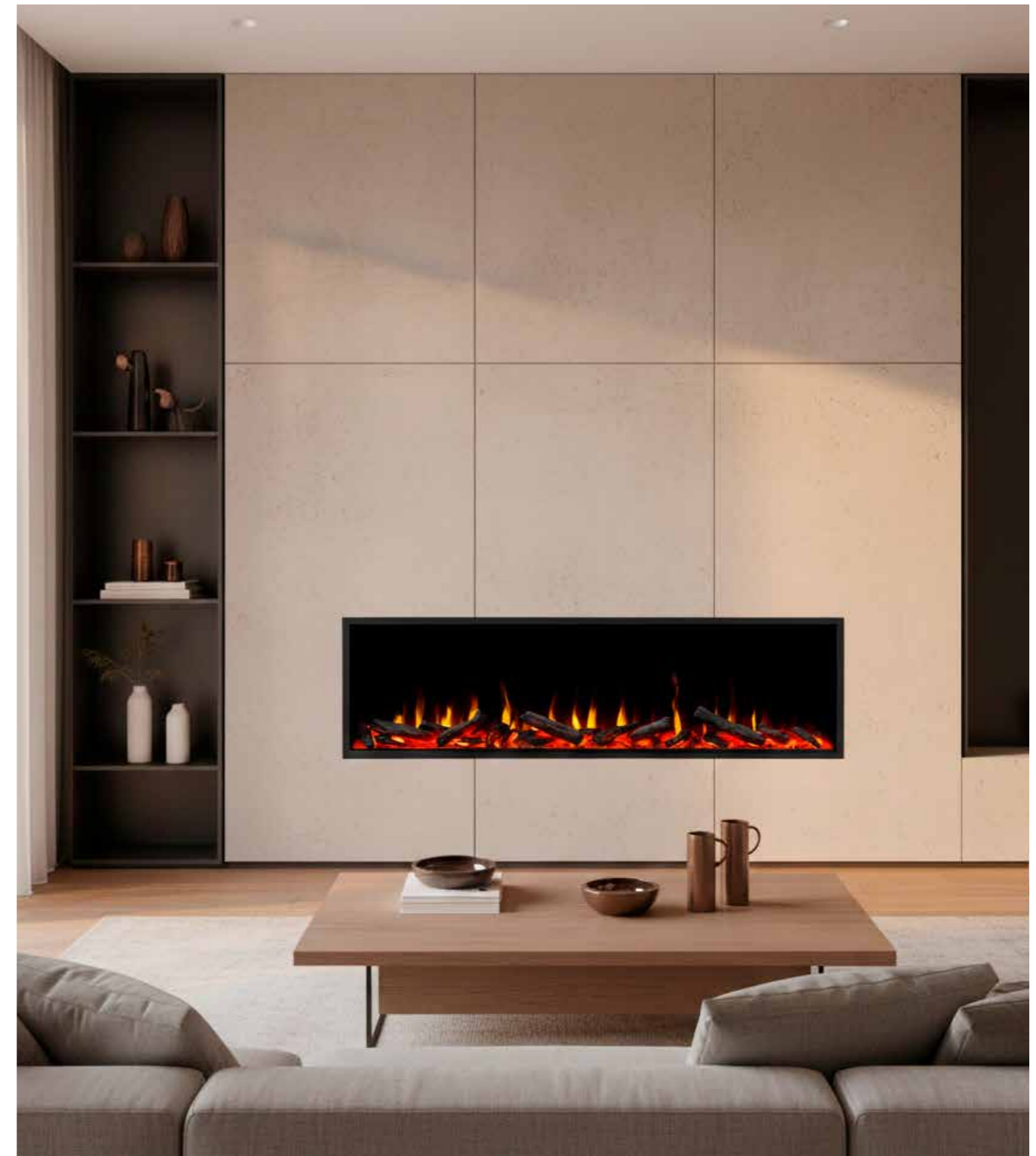

EU directives compliance  
LVD 2014/35/UE EMC 2014/30/UE  
DERP 2009/125/CE  
RoHS 2011/65/EU ((UE) 2015/863)

# CAMINETTO-GARDENA

025431158269

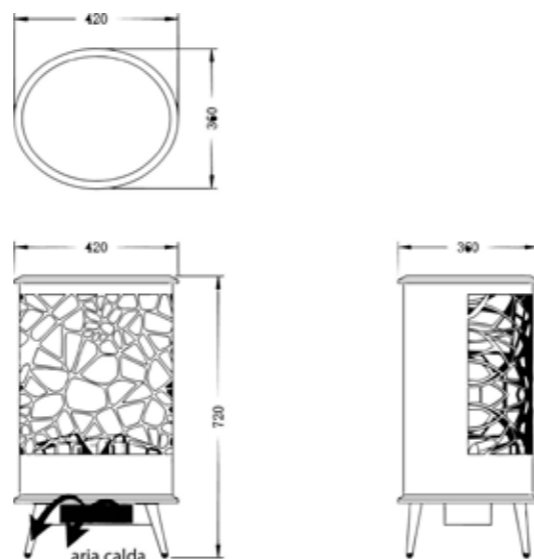

## CARATTERISTICHE/FEATURES

- **CAMINETTO ELETTRICO DA PAVIMENTO / FREE-STANDING ELECTRIC FIREPLACE**
- **MATERIALE: ACCIAIO/ MATERIAL: STEEL**
- **DIMENSIONI/DIMENSIONS 42X36X72 CM**
- **PESO/WEIGHT 35 KG**
- **CONTROLLO TOTALE TRAMITE TELECOMANDO O PANNELLO DI CONTROLLO  
FULL CONTROL VIA REMOTE CONTROL OR CONTROL PANEL**
- **EFFETTO FIAMMA OLOGRAFICO E STEREOSCOPICO ULTRA REALISTICO  
ULTRA-REALISTIC HOLOGRAPHIC AND STEREOSCOPIC FLAME EFFECT**
- **POTENZA / POWER 750-1500W**
- **ILLUMINAZIONE LED AD ALTA DEFINIZIONE  
DIMMABLE LED LIGHTING**
- **EFFETTO SONORO CREPITIO LEGNA  
SOUND EFFECT OF CRACKLING WOOD**
- **TECNOLOGIA OLOGRAFICA 3D  
3D HOLOGRAPHIC TECHNOLOGY**
- **L'ARIA CALDA ESCE DALLA PARTE INFERIORE DEL CAMINETTO  
HOT AIR COMES OUT OF THE BOTTOM OF THE FIREPLACE**

**DOPPIA MODALITÀ DI UTILIZZO: / DUAL MODE OF USE**

**CALORE CON EFFETTO FIAMMA E SUONO O SOLO  
EFFETTO FIAMMA DECORATIVO**

*HEAT WITH FLAME EFFECT AND SOUND, OR DECORATIVE  
FLAME EFFECT ONLY*



EU directives compliance  
LVD 2014/35/UE EMC 2014/30/UE  
DERP 2009/125/CE  
RoHS 2011/65/EU ((UE) 2015/863)

# CAMINETTI ELETTRICI DA PAVIMENTO ELECTRIC FLOOR STANDING FIREPLACE

CALORE, DESIGN ED EFFICIENZA SENZA PROBLEMI

SINED unisce innovazione ed eleganza per trasformare ogni spazio in un'atmosfera accogliente. I nostri caminetti elettrici a libera installazione sono la soluzione perfetta per chi vuole godere del calore del fuoco senza lavori di costruzione, fumo o manutenzione. All'interno della nostra esclusiva selezione, presentiamo due modelli eccezionali che ridefiniscono il comfort moderno: LIPARI e CALDERA.

WARMTH, DESIGN AND EFFICIENCY WITHOUT FUSS

*At SINED, we combine innovation and elegance to transform every space into a cosy atmosphere. Our free-standing electric fireplaces are the perfect solution for those who want to enjoy the warmth of fire without building work, smoke or maintenance. Within our exclusive selection, we present two outstanding models that redefine modern comfort: LIPARI and CALDERA.*



# CAMINO-CALDERA



-  WHITE RAL9001
-  DARK GRAY RAL7016
-  BLACK RAL9005

STOCK

BIANCO 8025431019447

GRIGIO 8025431019461

NERO 8025431019454

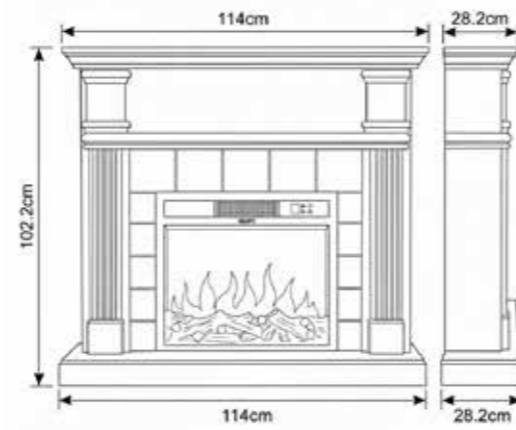

## CARATTERISTICHE/FEATURES

- **CAMINETTO ELETTRICO DA PAVIMENTO CON CORNICE IN LEGNO MDF**  
*ELECTRIC FLOOR STANDING FIREPLACE COMPOSED OF FLOORING WITH WOODEN MDF FRAME*
- **DIMENSIONI/DIMENSIONS 102,2X114X28,2 CM**
- **PESO/WEIGHT 37,3 KG**
- **MONTAGGIO DELLA CORNICE MOLTO SEMPLICE CON ISTRUZIONI PASSO PASSO**  
*VERY SIMPLE FRAME ASSEMBLY WITH STEP-BY-STEP INSTRUCTIONS*
- **EFFETTO FIAMMA LED ULTRA REALISTICO**  
*ULTRA-REALISTIC LED FLAME EFFECT*
- **POTENZA RISCALDAMENTO / ADJUSTABLE POWER 750-1500 W**
- **CONTROLLO TOTALE TRAMITE TELECOMANDO**  
*FULL CONTROL VIA REMOTE CONTROL*
- **INSTALLAZIONE CAMINETTO PLUG & PLAY, BASTA COLLEGARLO ALLA RETE ELETTRICA**  
*PLUG & PLAY FIREPLACE INSTALLATION, SIMPLY CONNECT TO THE POWER SUPPLY*
- **FUNZIONAMENTO SICURO: SENZA COMBUSTIONE, SENZA FUMO, SENZA CENERI**  
*SAFE OPERATION: NO COMBUSTION, NO SMOKE, NO ASH*

### DOPPIA MODALITÀ DI FUNZIONAMENTO / DUAL OPERATING MODE

**SOLO EFFETTO FIAMMA O RISCALDAMENTO CON TERMOVENTILATORE PCT DA 1500 W ERMETICAMENTE SIGILLATO**  
*DUAL OPERATING MODE: FLAME EFFECT ONLY OR HEATING WITH HERMETICALLY SEALED 1500 W PCT MOTOR*



**CORNICE IN LEGNO MADE IN ITALY**  
*WOODEN FRAME MADE IN ITALY*



EU directives compliance  
LVD 2014/35/UE EMC 2014/30/UE  
DERP 2009/125/CE  
RoHS 2011/65/EU ((UE) 2015/863)

# CAMINO-LIPARI



-  WHITE RAL9001
-  DARK GRAY RAL7016
-  BLACK RAL9005

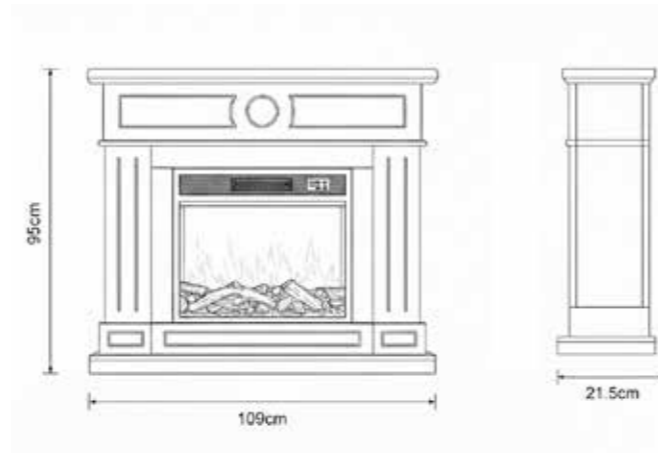

STOCK

BIANCO 8025431019485

GRIGIO 8025431019508

NERO 8025431019492

## CARATTERISTICHE/FEATURES

- **CAMINETTO ELETTRICO DA PAVIMENTO CON CORNICE IN LEGNO MDF**  
*ELECTRIC FLOOR STANDING FIREPLACE COMPOSED OF FLOORING WITH WOODEN MDF FRAME*
- **DIMENSIONI/DIMENSIONS 95X109X21,5 CM**
- **PESO/WEIGHT 37,3 KG**
- **MONTAGGIO DELLA CORNICE MOLTO SEMPLICE CON ISTRUZIONI PASSO PASSO**  
*VERY SIMPLE FRAME ASSEMBLY WITH STEP-BY-STEP INSTRUCTIONS*
- **EFFETTO FIAMMA LED ULTRA REALISTICO**  
*ULTRA-REALISTIC LED FLAME EFFECT*
- **POTENZA RISCALDAMENTO / ADJUSTABLE POWER 750-1500 W**
- **CONTROLLO TOTALE TRAMITE TELECOMANDO**  
*FULL CONTROL VIA REMOTE CONTROL*
- **INSTALLAZIONE CAMINETTO PLUG & PLAY, BASTA COLLEGARLO ALLA RETE ELETTRICA**  
*PLUG & PLAY FIREPLACE INSTALLATION, SIMPLY CONNECT TO THE POWER SUPPLY*
- **FUNZIONAMENTO SICURO: SENZA COMBUSTIONE, SENZA FUMO, SENZA CENERI**  
*SAFE OPERATION: NO COMBUSTION, NO SMOKE, NO ASH*

### DOPPIA MODALITÀ DI FUNZIONAMENTO / DUAL OPERATING MODE

**SOLO EFFETTO FIAMMA O RISCALDAMENTO CON TERMOVENTILATORE PCT DA 1500 W ERMETICAMENTE SIGILLATO**  
*DUAL OPERATING MODE: FLAME EFFECT ONLY OR HEATING WITH HERMETICALLY SEALED 1500 W PCT MOTOR*



**CORNICE IN LEGNO MADE IN ITALY**  
*WOODEN FRAME MADE IN ITALY*



EU directives compliance  
LVD 2014/35/UE EMC 2014/30/UE  
DERP 2009/125/CE  
RoHS 2011/65/EU ((UE) 2015/863)

# CAMINO-CALDERA-XXL



-  WHITE RAL9001
-  DARK GRAY RAL7016
-  BLACK RAL9005

STOCK

BIANCO 8025431155268

GRIGIO 8025431155541

NERO 8025431155558

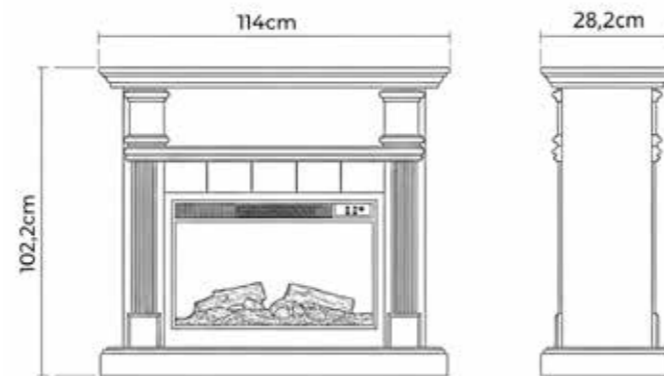

## CARATTERISTICHE/FEATURES

- **CAMINETTO ELETTRICO DA PAVIMENTO CON CORNICE IN LEGNO MDF**  
*ELECTRIC FLOOR STANDING FIREPLACE COMPOSED OF FLOORING WITH WOODEN MDF FRAME*
- **DIMENSIONI/DIMENSIONS 102,2X114X28,2 CM**
- **PESO/WEIGHT 37,3 KG**
- **MONTAGGIO DELLA CORNICE MOLTO SEMPLICE CON ISTRUZIONI PASSO PASSO**  
*VERY SIMPLE FRAME ASSEMBLY WITH STEP-BY-STEP INSTRUCTIONS*
- **EFFETTO FIAMMA LED ULTRA REALISTICO**  
*ULTRA-REALISTIC LED FLAME EFFECT*
- **POTENZA RISCALDAMENTO / ADJUSTABLE POWER 750-1500 W**
- **CONTROLLO TOTALE TRAMITE TELECOMANDO**  
*FULL CONTROL VIA REMOTE CONTROL*
- **INSTALLAZIONE CAMINETTO PLUG & PLAY, BASTA COLLEGARLO ALLA RETE ELETTRICA**  
*PLUG & PLAY FIREPLACE INSTALLATION, SIMPLY CONNECT TO THE POWER SUPPLY*
- **FUNZIONAMENTO SICURO: SENZA COMBUSTIONE, SENZA FUMO, SENZA CENERI**  
*SAFE OPERATION: NO COMBUSTION, NO SMOKE, NO ASH*

### DOPPIA MODALITÀ DI FUNZIONAMENTO / DUAL OPERATING MODE

**SOLO EFFETTO FIAMMA O RISCALDAMENTO CON TERMOVENTILATORE PCT DA 1500 W ERMETICAMENTE SIGILLATO**  
*DUAL OPERATING MODE: FLAME EFFECT ONLY OR HEATING WITH HERMETICALLY SEALED 1500 W PCT MOTOR*



**CORNICE IN LEGNO MADE IN ITALY**  
*WOODEN FRAME MADE IN ITALY*



EU directives compliance  
LVD 2014/35/UE EMC 2014/30/UE  
DERP 2009/125/CE  
RoHS 2011/65/EU ((UE) 2015/863)

# CAMINO-LIPARI-XXL



-  WHITE RAL9001
-  DARK GRAY RAL7016
-  BLACK RAL9005

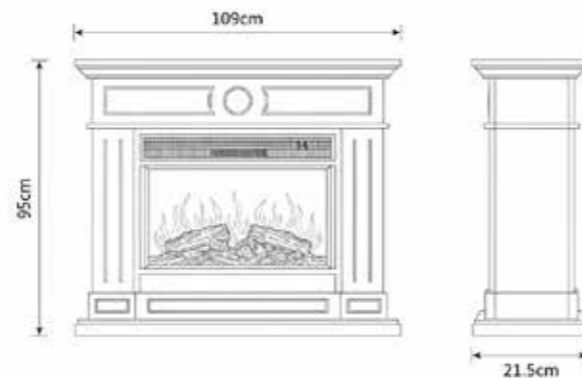

STOCK

BIANCO 8025431155251

GRIGIO 802543115527

NERO 802543115534

## CARATTERISTICHE/FEATURES

- **CAMINETTO ELETTRICO DA PAVIMENTO CON CORNICE IN LEGNO MDF**  
*ELECTRIC FLOOR STANDING FIREPLACE COMPOSED OF FLOORING WITH WOODEN MDF FRAME*
- **DIMENSIONI/DIMENSIONS 95X109X21,5 CM**
- **PESO/WEIGHT 37,3 KG**
- **MONTAGGIO DELLA CORNICE MOLTO SEMPLICE CON ISTRUZIONI PASSO PASSO**  
*VERY SIMPLE FRAME ASSEMBLY WITH STEP-BY-STEP INSTRUCTIONS*
- **EFFETTO FIAMMA LED ULTRA REALISTICO**  
*ULTRA-REALISTIC LED FLAME EFFECT*
- **POTENZA RISCALDAMENTO / ADJUSTABLE POWER 750-1500 W**
- **CONTROLLO TOTALE TRAMITE TELECOMANDO**  
*FULL CONTROL VIA REMOTE CONTROL*
- **INSTALLAZIONE CAMINETTO PLUG & PLAY, BASTA COLLEGARLO ALLA RETE ELETTRICA**  
*PLUG & PLAY FIREPLACE INSTALLATION, SIMPLY CONNECT TO THE POWER SUPPLY*
- **FUNZIONAMENTO SICURO: SENZA COMBUSTIONE, SENZA FUMO, SENZA CENERI**  
*SAFE OPERATION: NO COMBUSTION, NO SMOKE, NO ASH*

### DOPPIA MODALITÀ DI FUNZIONAMENTO / DUAL OPERATING MODE

**SOLO EFFETTO FIAMMA O RISCALDAMENTO CON TERMOVENTILATORE PCT DA 1500 W ERMETICAMENTE SIGILLATO**  
*DUAL OPERATING MODE: FLAME EFFECT ONLY OR HEATING WITH HERMETICALLY SEALED 1500 W PCT MOTOR*



CORNICE IN LEGNO MADE IN ITALY  
WOODEN FRAME MADE IN ITALY



EU directives compliance  
LVD 2014/35/UE EMC 2014/30/UE  
DERP 2009/125/CE  
RoHS 2011/65/EU ((UE) 2015/863)

# RISCALDATORI TERMOPELLET

## THERMOPELLET HEATERS

Una collezione di riscaldatori a pellet progettata per trasformare gli spazi outdoor in ambienti accoglienti e utilizzabili tutto l'anno.

Linee essenziali, struttura compatta e una presenza elegante si uniscono all'efficienza del combustibile biomassa, offrendo un calore confortevole e sostenibile.

Questi sistemi garantiscono alte prestazioni con consumi ottimizzati e gestione intuitiva.

La tecnologia a pellet consente una diffusione uniforme del calore, riducendo l'impatto ambientale senza rinunciare al comfort.

Una soluzione moderna che coniuga design, efficienza energetica e benessere outdoor.

*A collection of pellet heaters designed to transform outdoor spaces into cosy areas that can be enjoyed all year round. Clean lines, a compact design and an elegant appearance combine with the efficiency of biomass fuel to provide comfortable, sustainable warmth.*

*These systems deliver high performance with optimised fuel consumption and intuitive operation. Pellet technology allows for even heat distribution, reducing environmental impact without compromising on comfort. A modern solution that combines design, energy efficiency and outdoor well-being.*



# TERMOPELLET-ARIA

8025431021624

MADE IN ITALY

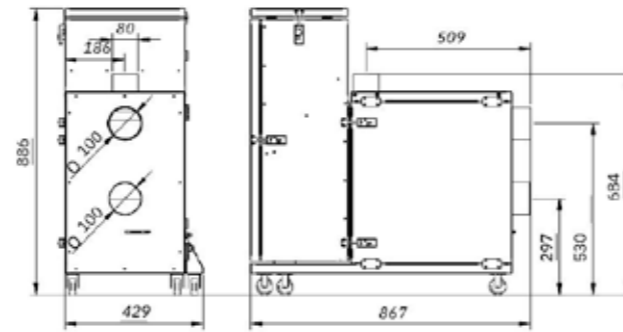

\*DISPONIBILE SOLO SU ORDINAZIONE  
\*AVAILABLE ONLY UPON REQUEST

## CARATTERISTICHE/FEATURES

- **IDEALE PER PERGOLE, VERANDE MA ADDATO ANCHE AD AMBIENTI INTERNI**
- **DIMENSIONI/DIMENSIONS 86X43X89 CM**
- **PESO/WEIGHT 70,80 KG**
- **POTENZA/POWER 12 KW**
- **VOLUME RISCALDABILE / HEATED VOLUME 120 M2**
- **FREQUENZA DI PULIZIA / CLEANING FREQUENCY 10 GIORNI**
- **TELECOMANDO INTELLIGENTE / SMART REMOTE CONTROL**
- **RENDIMENTO/EFFICIENCY 85%**
- **LIVELLI DI POTENZA / POWER LEVELS 5**
- **CAPACITÀ SERBATOIO PELLETTA / PELLET TANK CAPACITY 18/50 KG**
- **CONSUMO ORARIO / HOURLY CONSUMPTION 0,9 MIN. KG/H**
- **AUTONOMIA ALLA MINIMA POTENZA / RANGE AT MINIMUM POWER 25H**
- **USCITA FUMI / EXHAUST OUTLET Ø 80MM**
- **USCITA ARIA - ENTRATA ARIA / AIR OUTLET - AIR INLET Ø 100MM**
- **COMBUSTIBILI UTILIZZABILI / LOW CONSUME POWER PELLETTA A1/PELLET A2 DI FAGGIO O ABETE**
- **NESSUNA CANNA FUMARIA / NO FLUE**
- **TRASPORTABILI/ PORTABLE**



## COME FUNZIONA?

IL TERMOPELLET VA INSTALLATO ALL'ESTERNO DELL'EDIFICIO DA RISCALDARE: SI PRATICANO DUE FORI NELLA PARETE, UNO PER ASPIRARE L'ARIA FREDDA DALL'AMBIENTE INTERNO E L'ALTRO PER REIMMETTERLA DOPO AVERLA RISCALDATA GRAZIE ALLA COMBUSTIONE DEL PELLETTA. IL TERMOPELLET PUÒ ESSERE CONTROLLATO INTERAMENTE A DISTANZA TRAMITE IL TELECOMANDO INTELLIGENTE, CHE FUNGE ANCHE DA TERMOSTATO ALL'INTERNO DELL'EDIFICIO.

## HOW DOES IT WORK?

THE TURBOPELLET IS INSTALLED OUTSIDE THE BUILDING TO BE HEATED: TWO HOLES ARE DRILLED IN THE WALL, ONE TO DRAW IN COLD AIR FROM INSIDE THE BUILDING AND THE OTHER TO RETURN IT ONCE IT HAS BEEN HEATED BY THE COMBUSTION OF THE PELLETTA. THE TURBOPELLET CAN BE FULLY CONTROLLED REMOTELY USING THE SMART REMOTE CONTROL, WHICH ALSO ACTS AS A THERMOSTAT INSIDE THE BUILDING.

# TERMO ARREDI

## HEATING FURNITURE

Una collezione di termoarredi elettrici pensata per integrare comfort e design in un'unica presenza essenziale.

Forme scultoree, superfici materiche e geometrie contemporanee trasformano il radiatore in un elemento d'arredo capace di dialogare con l'architettura dello spazio.

Ideali per bagni, zone wellness e ambienti residenziali sofisticati, uniscono efficienza termica ed eleganza minimale.

Una nuova interpretazione del calore domestico, dove tecnologia e stile convivono con equilibrio e discrezione.

*A collection of electric radiators designed to combine comfort and aesthetics in one essential presence.*

*Sculptural forms, textured surfaces and contemporary geometries transform the radiator into a true design element that interacts naturally with the surrounding architecture.*

*Ideal for bathrooms, wellness areas and sophisticated residential interiors, they merge thermal efficiency with minimalist elegance.*

*A modern interpretation of home heating, where technology and style coexist with balance and subtlety.*

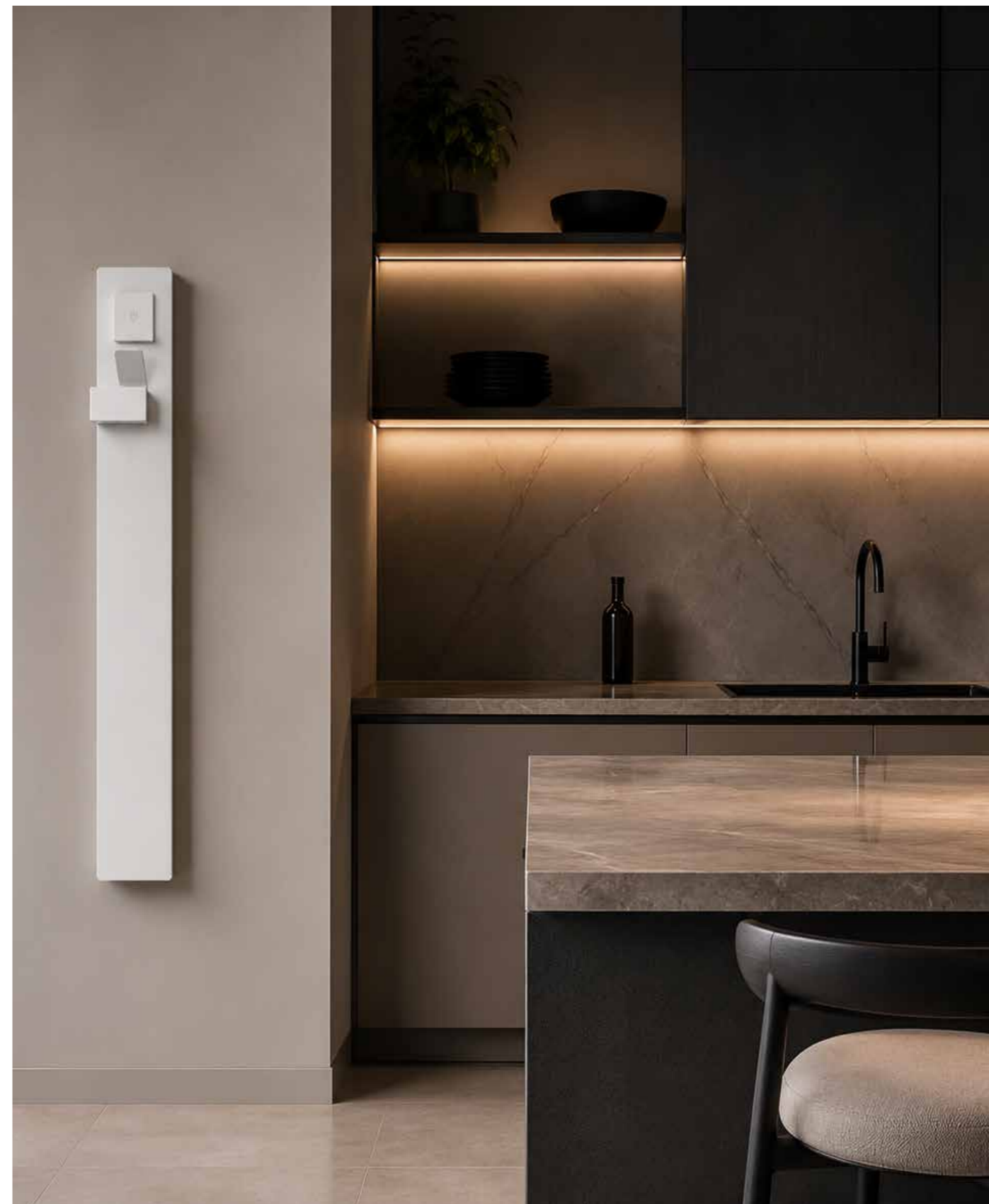

# TERMOARREDO-GRIES-BIANCO

8025431021600

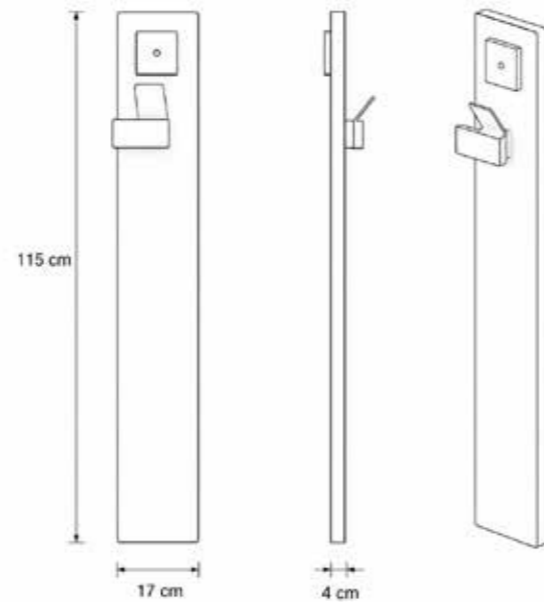

\*ALTRI COLORI DISPONIBILE SOLO SU ORDINAZIONE  
\*OTHER COLOURS AVAILABLE ONLY UPON REQUEST



## CARATTERISTICHE/FEATURES

MADE IN ITALY



- **MATERIALE POLVERE DI MARMO**  
*MATERIAL MARBLE POWDER*
- **DIMENSIONI/DIMENSIONS 115X17X4 CM**
- **POTENZA/POWER 250 W**
- **RADIATORE ELETTRICO VERTICALE DA PARETE / VERTICAL ELECTRIC WALL-MOUNTED RADIATOR**
- **INSTALLAZIONE VERTICALE SALVASPAZIO / SPACE-SAVING VERTICAL INSTALLATION**
- **FUNZIONE SCALDASALVIETTE INTEGRATA / INTEGRATED TOWEL HOLDER FUNCTION**
- **RISCALDAMENTO ELETTRICO A BASSO CONSUMO / LOW ENERGY ELECTRIC HEATING**
- **STRUTTURA RESISTENTE E DUREVOLE / DURABLE AND RESISTANT STRUCTURE**
- **IDEALE PER BAGNO, CUCINA E AMBIENTI MODERNI / IDEAL FOR BATHROOMS, KITCHENS AND MODERN INTERIORS**
- **TERMOSTATO E APP WIFI CON ALEXA INCLUSO / THERMOSTAT AND WI-FI APP WITH**
- **ECOLOGICI E A RISPARMIO ENERGETICO / ECO-FRIENDLY AND ENERGY-EFFICIENT**



# TERMOARREDO-TOSCANA-BIANCO

## by MAARMO

600W 8025431021662

1000W 8025431021679

1400W 8025431021686



\*ALTRI COLORI DISPONIBILE SOLO SU ORDINAZIONE  
\*OTHER COLOURS AVAILABLE ONLY UPON REQUEST



MADE IN ITALY



### CARATTERISTICHE/FEATURES

- **MATERIALE POLVERE DI MARMO**  
*MATERIAL MARBLE POWDER*
- **3 DIMENSIONI DIVERSE / 3 DIFFERENT DIMENSIONS 55X110 CM, 55X150CM, 55X180CM**
- **POTENZA/POWER 250 W**
- **RADIATORE ELETTRICO VERTICALE DA PARETE / VERTICAL ELECTRIC WALL-MOUNTED RADIATOR**
- **INSTALLAZIONE VERTICALE O ORIZZONTALE / SPACE-SAVING VERTICAL AND HORIZONTAL**
- **FUNZIONE SCALDASALVIETTE INTEGRATA / INTEGRATED TOWEL HOLDER FUNCTION**
- **RISCALDAMENTO ELETTRICO A BASSO CONSUMO / LOW ENERGY ELECTRIC HEATING**
- **STRUTTURA RESISTENTE E DUREVOLE / DURABLE AND RESISTANT STRUCTURE**
- **IDEALE PER BAGNO, CUCINA E AMBIENTI MODERNI / IDEAL FOR BATHROOMS, KITCHENS AND MODERN INTERIORS**
- **TERMOSTATO CON TELECOMANDO BLUETOOTH / THERMOSTAT WITH BLUETOOTH CONTROL INCLUDED**
- **EFFETTO PIETRA / STONE EFFECT**
- **ECOLOGICI E A RISPARMIO ENERGETICO / ECO-FRIENDLY AND ENERGY-EFFICIENT**



# RISCALDATORI INFRAROSSI

SINED amplia la propria proposta commerciale introducendo una nuova gamma di **lampade riscaldanti a infrarossi** progettate per offrire una soluzione efficace, elegante e versatile al riscaldamento di ambienti esterni durante le mezze stagioni. In un contesto in cui bar, ristoranti, terrazze, dehors, gazebo e ambienti semi-aperti cercano sempre più frequentemente soluzioni per garantire comfort ai clienti anche nei periodi più freschi, le lampade infrarossi SINED si presentano come la risposta ideale: **pronte all'uso, efficienti e silenziose**, senza costi di installazione complessi né manutenzione ordinaria.

La gamma si distingue per l'integrazione di **due tecnologie di riscaldamento** a infrarossi, ciascuna pensata per esigenze specifiche. La **tecnologia a onda corta** consente un riscaldamento immediato e diretto, ideale per spazi esposti o ventilati. Grazie all'elevata intensità del calore emesso, queste lampade sono perfette per attività commerciali che necessitano di un'azione rapida, come i tavoli all'aperto di bar e ristoranti o le aree ad alto ricambio di persone. L'effetto è percepibile in meno di un secondo, garantendo una sensazione di benessere istantanea.

Le **lampade a onda lunga**, invece, offrono un rilascio di calore più lento e uniforme, generando un comfort termico prolungato e gradevole, ideale per permanenze più lunghe in spazi parzialmente chiusi o protetti, come pergolati, verande o terrazze coperte. Questa tecnologia è apprezzata non solo per la sua efficacia, ma anche per i **benefici sulla salute**, grazie all'azione del calore profondo che stimola la microcircolazione e favorisce il rilassamento muscolare.



# INFRARATED HEATER

SINED is expanding its commercial proposition by introducing a new range of **infrared heating lamps** designed to offer an effective, elegant and versatile solution to outdoor space heating during the mid-season. In a context where bars, restaurants, terraces, dehors, gazebos and semi-open spaces are increasingly looking for solutions to guarantee comfort to customers even in the cooler periods, SINED's infrared lamps present themselves as the ideal answer: **ready to use, efficient and silent**, without complex installation costs or routine maintenance.

The range is characterised by the integration of **two infrared heating technologies**, each designed for specific needs. **The short-wave technology** provides immediate and direct heating, ideal for exposed or ventilated spaces. Due to the high intensity of the emitted heat, these lamps are perfect for commercial activities that require quick action, such as outdoor tables in bars and restaurants or areas with a high turnover of people. The effect can be felt in less than a second, providing an instant feeling of well-being.

**Long-wave lamps**, on the other hand, offer a slower and more uniform heat release, generating a prolonged and pleasant thermal comfort, ideal for longer stays in partially enclosed or protected spaces such as pergolas, verandas or covered terraces. This technology is appreciated not only for its effectiveness, but also for its **health benefits**, thanks to the action of deep heat that stimulates microcirculation and promotes muscle relaxation.



# CALDO-I-BOX

8025431016569

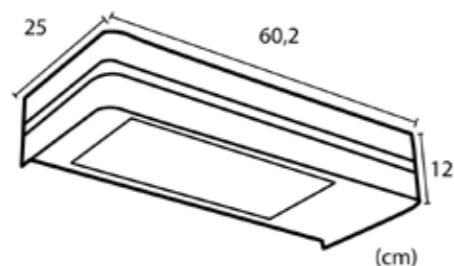

## CARATTERISTICHE/FEATURES

- **RISCALDATORE INFRAROSSI ONDA CORTA IR-A**
- **MATERIALE: ALLUMINIO/ MATERIAL: ALUMINIUM**
- **DIMENSIONI/DIMENSIONS 60,2X25X12 CM**
- **PESO/WEIGHT 2,9 KG**
- **POTENZA 2000W REGOLABILE SU 3 LIVELLI / POWER 2000W ADJUSTABLE TO 3 LEVELS**
- **TECNOLOGIA A INFRAROSSI A ONDE CORTE, CALORE IMMEDIATO**  
*SHORTWAVE INFRARED TECHNOLOGY, INSTANT HEAT*
- **FORMATO COMPATTO TIPO "BOX" / COMPACT BOX-TYPE FORMAT**
- **AREA DI RISCALDAMENTO ASIMMETRICA**  
*ASYMMETRICAL HEATING AREA*
- **PARTICOLARMENTE ADATTO PER HOTEL, BAR, RISTORANTI, TERRAZZE E DEHORS**  
*PARTICULARLY SUITABLE FOR HOTELS, BARS, RESTAURANTS, TERRACES AND OUTDOOR SEATING AREAS*
- **SI APPENDE DIRETTAMENTE SULLA PARETE**  
*HANGS DIRECTLY ON THE WALL*
- **ACCENSIONE ISTANTANEA, SENZA TEMPI DI PRERISCALDAMENTO**  
*INSTANT IGNITION, NO PREHEATING REQUIRED*
- **CONTROLLO TOTALE TRAMITE TELECOMANDO INCLUSO (LE BATTERIE NON SONO INCLUSE)**  
*FULL CONTROL VIA REMOTE CONTROL (BATTERIES NOT INCLUDED)*
- **LAMPADA LOW GLARING ANTIABBAGLIAMENTO**  
*LOW GLARING LAMP*

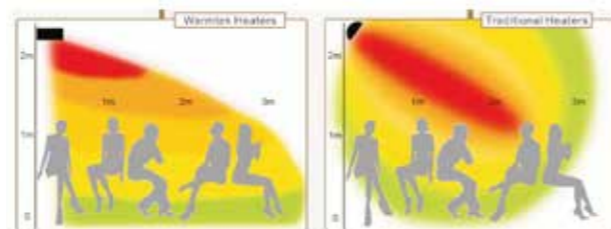

### PARTICOLARITÀ / SPECIAL FEATURE

**CONSENTE DI DIRIGERE IL CALORE IN MODO PRECISO SOLO VERSO LA ZONA DESIDERATA, EVITANDO DISPERSIONI E OTTIMIZZANDO IL CONSUMO ENERGETICO**  
*ALLOWS HEAT TO BE DIRECTED PRECISELY TO THE DESIRED AREA,*



EU directives compliance  
LVD 2014/35/UE EMC 2014/30/UE  
DERP 2009/125/CE  
RoHS 2011/65/EU ((UE) 2015/863)

# CALDO-IRA-INOX

STOCK

2000W 8025431016576

2000W-WIFI 8025431018822 

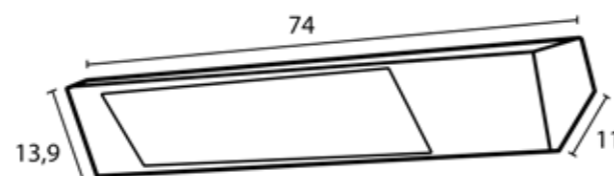

## CARATTERISTICHE/FEATURES

- **RISCALDATORE INFRAROSSI ONDA CORTA IR-A / SHORTWAVE INFRARED HEATER IR-A**
- **MATERIALE: ALLUMINIO / MATERIAL: ALUMINIUM**
- **DIMENSIONI / DIMENSIONS 74,2X218X13,9 CM**
- **PESO / WEIGHT 2,9 KG**
- **POTENZA 2000W REGOLABILE SU 3 LIVELLI / POWER 2000W ADJUSTABLE TO 3 LEVELS**
- **TECNOLOGIA A INFRAROSSI A ONDE CORTE IR-A, CALORE IMMEDIATO**  
*SHORTWAVE IR-A INFRARED TECHNOLOGY, INSTANT HEAT*
- **PARTICOLARMENTE ADATTO PER HOTEL, BAR, RISTORANTI, TERRAZZE E DEHORS**  
*PARTICULARLY SUITABLE FOR HOTELS, BARS, RESTAURANTS, TERRACES AND OUTDOOR SEATING AREAS*
- **MONTAGGIO A PARETE O A SOFFITTO CON LE STAFFE REGOLABILI IN DOTAZIONE**  
*WALL OR CEILING MOUNTING WITH THE ADJUSTABLE BRACKETS PROVIDED*
- **ACCENSIONE Istantanea, SENZA TEMPI DI PRERISCALDAMENTO**  
*INSTANT IGNITION, NO PREHEATING REQUIRED*
- **CONTROLLO TOTALE TRAMITE TELECOMANDO INCLUSO (LE BATTERIE NON SONO INCLUSE)**  
*FULL CONTROL VIA REMOTE CONTROL (BATTERIES NOT INCLUDED)*
- **LAMPADA LOW GLARING ANTIABBAGLIAMENTO E ANTIRIFLESSO**  
*LOW GLARING AND ANTI-REFLECTIVE LAMP*
- **TIMER PROGRAMMABILE PER SPEGNIMENTO AUTOMATICO**  
*PROGRAMMABLE TIMER FOR AUTOMATIC SWITCH-OFF*

### PARTICOLARITÀ / SPECIAL FEATURE

**CONSENTE DI DIRIGERE IL CALORE IN MODO PRECISO SOLO VERSO LA ZONA DESIDERATA, EVITANDO DISPERSIONI E OTTIMIZZANDO IL CONSUMO ENERGETICO**  
*ALLOWS HEAT TO BE DIRECTED PRECISELY TO THE DESIRED AREA, AVOIDING DISPERSION AND OPTIMISING ENERGY CONSUMPTION*



EU directives compliance  
LVD 2014/35/UE EMC 2014/30/UE  
DERP 2009/125/CE  
RoHS 2011/65/EU ((UE) 2015/863)



# CALDO-IRA-INOX

STOCK

**PALO** 8025431016583

**PALO-WIFI** 8025431018839 

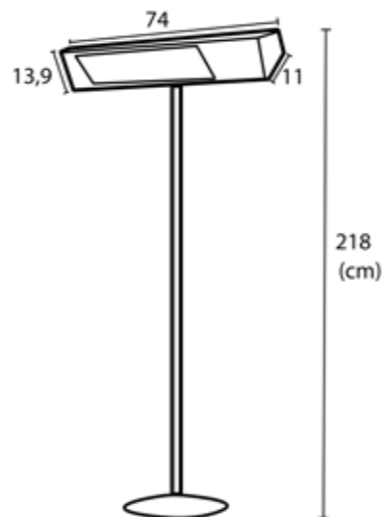

## CARATTERISTICHE/FEATURES

- **RISCALDATORE INFRAROSSI ONDA CORTA IR-A / SHORTWAVE INFRARED HEATER IR-A**
- **MATERIALE: ALLUMINIO / MATERIAL: ALUMINIUM**
- **DIMENSIONI / DIMENSIONS 80X21,5X23 CM**
- **PESO / WEIGHT 22,6 KG**
- **POTENZA 2000W REGOLABILE SU 3 LIVELLI / POWER 2000W ADJUSTABLE TO 3 LEVELS**
- **TECNOLOGIA A INFRAROSSI A ONDE CORTE IR-A, CALORE IMMEDIATO**  
*SHORTWAVE IR-A INFRARED TECHNOLOGY, INSTANT HEAT*
- **PARTICOLARMENTE ADATTO PER HOTEL, BAR, RISTORANTI, TERRAZZE E DEHORS**  
*PARTICULARLY SUITABLE FOR HOTELS, BARS, RESTAURANTS, TERRACES AND OUTDOOR SEATING AREAS*
- **KIT RISCALDATORE INFRAROSSI CALDO-IRA-INOX + SUPPORTO-RISCALDATORE (PAG X)**
- **ACCENSIONE Istantanea, SENZA TEMPI DI PRERISCALDAMENTO**  
*INSTANT IGNITION, NO PREHEATING REQUIRED*
- **CONTROLLO TOTALE TRAMITE TELECOMANDO INCLUSO (LE BATTERIE NON SONO INCLUSE)**  
*FULL CONTROL VIA REMOTE CONTROL (BATTERIES NOT INCLUDED)*
- **LAMPADA LOW GLARING ANTIABBAGLIAMENTO E ANTIRIFLESSO**  
*LOW GLARING AND ANTI-REFLECTIVE LAMP*
- **TIMER PROGRAMMABILE PER SPEGNIMENTO AUTOMATICO**  
*PROGRAMMABLE TIMER FOR AUTOMATIC SWITCH-OFF*
- **IL PALO ANTIRIBALTAMENTO CONSENTE DI POSIZIONARE FACILMENTE IL RISCALDATORE DOVE SERVE DI PIU'**  
*THE ANTI-TIP POLE ALLOWS YOU TO EASILY POSITION THE HEATER WHERE IT IS MOST NEEDED*



### PARTICOLARITÀ / SPECIAL FEATURE

**CONSENTE DI DIRIGERE IL CALORE IN MODO PRECISO SOLO VERSO LA ZONA DESIDERATA, EVITANDO DISPERSIONI E OTTIMIZZANDO IL CONSUMO ENERGETICO**  
*ALLOWS HEAT TO BE DIRECTED PRECISELY TO THE DESIRED AREA, AVOIDING DISPERSION AND OPTIMISING ENERGY CONSUMPTION*



EU directives compliance  
LVD 2014/35/UE EMC 2014/30/UE  
DERP 2009/125/CE  
RoHS 2011/65/EU ((UE) 2015/863)

# CALDO-VETRO-NERO-2000-WIFI

8025431018846

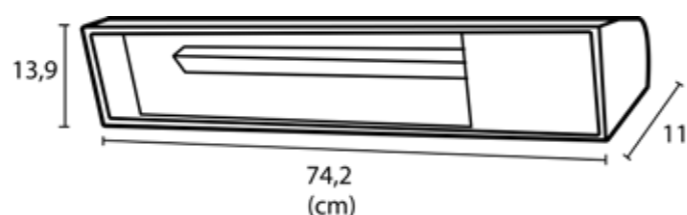

## CARATTERISTICHE/FEATURES

- **RISCALDATORE INFRAROSSI VETRO BLACK SCHOTT ONDA CORTA IR-A**  
*SHORTWAVE BLACK INFRARED GLASS HEATER IR-A*
- **MATERIALE: ALLUMINIO/ MATERIAL: ALUMINIUM**
- **DIMENSIONI/DIMENSIONS 13,9X11X74,2 CM**
- **PESO/WEIGHT 3,2 KG**
- **POTENZA 2000W REGOLABILE SU 3 LIVELLI / POWER 2000W ADJUSTABLE TO 3 LEVELS**
- **TECNOLOGIA A INFRAROSSI A ONDE CORTE IR-A, CALORE IMMEDIATO**  
*SHORTWAVE IR-A INFRARED TECHNOLOGY, INSTANT HEAT*
- **PARTICOLARMENTE ADATTO PER HOTEL, BAR, RISTORANTI, TERRAZZE E DEHORS**  
*PARTICULARLY SUITABLE FOR HOTELS, BARS, RESTAURANTS, TERRACES AND OUTDOOR SEATING AREAS*
- **MONTAGGIO A PARETE, A SOFFITTO O CON PIEDISTALLO OPZIONALE**  
*WALL MOUNTING, CEILING OR WITH OPTIONAL PEDESTAL*
- **ACCENSIONE Istantanea, SENZA TEMPI DI PRERISCALDAMENTO**  
*INSTANT IGNITION, NO PREHEATING REQUIRED*
- **CONTROLLO TOTALE TRAMITE TELECOMANDO INCLUSO (LE BATTERIE NON SONO INCLUSE)**  
*FULL CONTROL VIA REMOTE CONTROL (BATTERIES NOT INCLUDED)*
- **LAMPADA LOW GLARING ANTIABBAGLIAMENTO E ANTIRIFLESSO**  
*LOW GLARING AND ANTI-REFLECTIVE LAMP*
- **TIMER PROGRAMMABILE PER SPEGNIMENTO AUTOMATICO**  
*PROGRAMMABLE TIMER FOR AUTOMATIC SWITCH-OFF*

### PARTICOLARITÀ / SPECIAL FEATURE

**LA LUCE NON COLPISCE DIRETTAMENTE GLI OCCHI PERCHÉ IL VETRO NERO BLACK SCHOTT RIDUCE L'EMISSIONE DI LUCE E RADIAZIONI NOCIVE CONSENTENDO UNA ELEVATA TRASMISSIONE DEL CALORE**  
*THE LIGHT DOES NOT DIRECTLY HIT THE EYES BECAUSE BLACK SCHOTT GLASS REDUCES THE EMISSION OF LIGHT AND HARMFUL RADIATION, ALLOWING HIGH HEAT TRANSMISSION.*



EU directives compliance  
LVD 2014/35/UE EMC 2014/30/UE  
DERP 2009/125/CE  
RoHS 2011/65/EU ((UE) 2015/863)

# CALDO-VETRO-NERO-PIEDISTALLO-WIFI

8025431018853

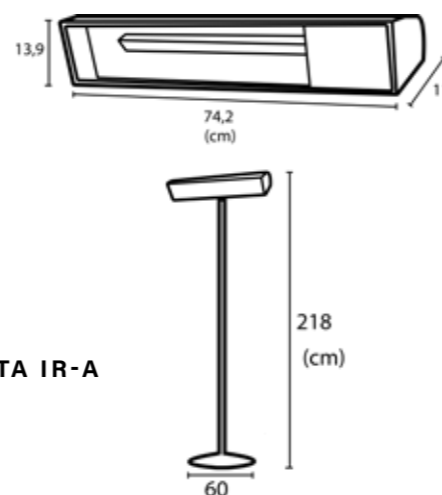

## CARATTERISTICHE/FEATURES

- **RISCALDATORE INFRAROSSI VETRO BLACK SCHOTT ONDA CORTA IR-A**  
*SHORTWAVE BLACK INFRARED GLASS HEATER IR-A*
- **MATERIALE: ALLUMINIO/ MATERIAL: ALUMINIUM**
- **DIMENSIONI/DIMENSIONS 218X74,2X11 CM**
- **PESO/WEIGHT 21,2 KG**
- **POTENZA 2000W REGOLABILE SU 3 LIVELLI / POWER 2000W ADJUSTABLE TO 3 LEVELS**
- **TECNOLOGIA A INFRAROSSI A ONDE CORTE IR-A, CALORE IMMEDIATO**  
*SHORTWAVE IR-A INFRARED TECHNOLOGY, INSTANT HEAT*
- **PARTICOLARMENTE ADATTO PER HOTEL, BAR, RISTORANTI, TERRAZZE E DEHORS**  
*PARTICULARLY SUITABLE FOR HOTELS, BARS, RESTAURANTS, TERRACES AND OUTDOOR SEATING AREAS*
- **KIT RISCALDATORE INFRAROSSI CALDO-VETRO-NERO-WIFI + SUPPORTO-RISCALDATORE**
- **ACCENSIONE ISTANTANEA, SENZA TEMPI DI PRERISCALDAMENTO**  
*INSTANT IGNITION, NO PREHEATING REQUIRED*
- **CONTROLLO TOTALE TRAMITE TELECOMANDO INCLUSO (LE BATTERIE NON SONO INCLUSE)**  
*FULL CONTROL VIA REMOTE CONTROL (BATTERIES NOT INCLUDED)*
- **LAMPADA LOW GLARING ANTIABBAGLIAMENTO E ANTIRIFLESSO**  
*LOW GLARING AND ANTI-REFLECTIVE LAMP*
- **TIMER PROGRAMMABILE PER SPEGNIMENTO AUTOMATICO**  
*PROGRAMMABLE TIMER FOR AUTOMATIC SWITCH-OFF*
- **IL PALO ANTIRIBALTAMENTO CONSENTE DI POSIZIONARE FACILMENTE IL RISCALDATORE DOVE SERVE DI PIU'**  
*THE ANTI-TIP POLE ALLOWS YOU TO EASILY POSITION THE HEATER WHERE IT IS MOST NEEDED*



### PARTICOLARITÀ / SPECIAL FEATURE

**LA LUCE NON COLPISCE DIRETTAMENTE GLI OCCHI PERCHÉ IL VETRO NERO BLACK SCHOTT RIDUCE L'EMISSIONE DI LUCE E RADIAZIONI NOCIVE CONSENTENDO UNA ELEVATA TRASMISSIONE DEL CALORE**  
*THE LIGHT DOES NOT DIRECTLY HIT THE EYES BECAUSE BLACK SCHOTT GLASS REDUCES THE EMISSION OF LIGHT AND HARMFUL RADIATION, ALLOWING HIGH HEAT TRANSMISSION.*



EU directives compliance  
LVD 2014/35/UE EMC 2014/30/UE  
DERP 2009/125/CE  
RoHS 2011/65/EU ((UE) 2015/863)

# STUFA-INFRAROSSI-PARETE-2000

8025431012295

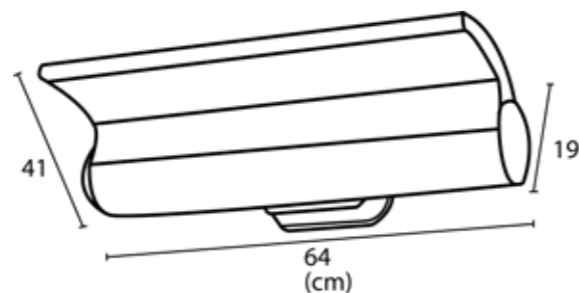

## CARATTERISTICHE/FEATURES

- **RISCALDATORE INFRAROSSI DI DESIGN ONDA CORTA IR-A / SHORTWAVE INFRARED HEATER**
- **MATERIALE: ALLUMINIO / MATERIAL: ALUMINIUM**
- **DIMENSIONI / DIMENSIONS 64X19X41 CM**
- **PESO / WEIGHT 3,8 KG**
- **POTENZA 2000W REGOLABILE SU 3 LIVELLI / POWER 2000W ADJUSTABLE TO 3 LEVELS**
- **TECNOLOGIA A INFRAROSSI A ONDE CORTE IR-A, CALORE IMMEDIATO**  
*SHORTWAVE IR-A INFRARED TECHNOLOGY, INSTANT HEAT*
- **PARTICOLARMENTE ADATTO PER HOTEL, BAR, RISTORANTI, TERRAZZE E DEHORS**  
*PARTICULARLY SUITABLE FOR HOTELS, BARS, RESTAURANTS, TERRACES AND OUTDOOR SEATING AREAS*
- **MONTAGGIO A PARETE O CON PIEDISTALLO OPZIONALE**  
*WALL MOUNTING OR WITH OPTIONAL PEDESTAL*
- **ACCENSIONE ISTANTANEA, SENZA TEMPI DI PRERISCALDAMENTO**  
*INSTANT IGNITION, NO PREHEATING REQUIRED*
- **CONTROLLO TOTALE TRAMITE TELECOMANDO INCLUSO (LE BATTERIE NON SONO INCLUSE)**  
*FULL CONTROL VIA REMOTE CONTROL (BATTERIES NOT INCLUDED)*
- **LAMPADA LOW GLARING ANTIABBAGLIAMENTO E ANTIRIFLESSO**  
*LOW GLARING AND ANTI-REFLECTIVE LAMP*
- **TIMER PROGRAMMABILE PER SPEGNIMENTO AUTOMATICO**  
*PROGRAMMABLE TIMER FOR AUTOMATIC SWITCH-OFF*

### **PARTICOLARITÀ / SPECIAL FEATURE**

**LA LUCE NON COLPISCE DIRETTAMENTE GLI OCCHI PERCHÉ VIENE RIFLESSA DA UNO SPECCHIO CURVO CHE CONSENTE DI CONCENTRARE IL CALORE IN MODO PRECISO SOLO VERSO LA ZONA DESIDERATA**

*THE LIGHT DOES NOT STRIKE THE EYES DIRECTLY BECAUSE IT IS REFLECTED BY A CURVED MIRROR THAT ALLOWS THE HEAT TO BE CONCENTRATED PRECISELY ON THE DESIRED AREA AVOIDING DISPERSION AND OPTIMISING ENERGY CONSUMPTION*



EU directives compliance  
LVD 2014/35/UE EMC 2014/30/UE  
DERP 2009/125/CE  
RoHS 2011/65/EU ((UE) 2015/863)

# STUFA-INFRAROSSI-SOFFITTO-4000

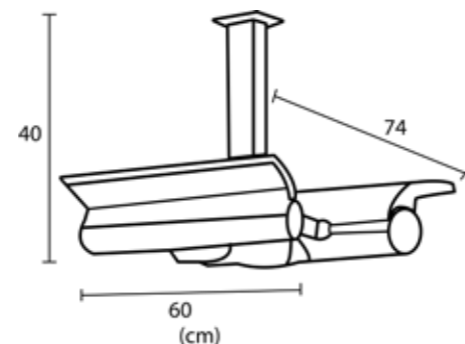

## CARATTERISTICHE/FEATURES

- **RISCALDATORE INFRAROSSI ONDA CORTA IR-A / SHORTWAVE INFRARED HEATER IR-A**
- **MATERIALE: ALLUMINIO/ MATERIAL: ALUMINIUM**
- **DIMENSIONI/DIMENSIONS 40X60X74 CM**
- **PESO/WEIGHT 10 KG**
- **POTENZA 4000W REGOLABILE SU 3 LIVELLI / POWER 4000W ADJUSTABLE TO 3 LEVELS**
- **TECNOLOGIA A INFRAROSSI A ONDE CORTE IR-A, CALORE IMMEDIATO**  
*SHORTWAVE IR-A INFRARED TECHNOLOGY, INSTANT HEAT*
- **PARTICOLARMENTE ADATTO PER HOTEL, BAR, RISTORANTI, TERRAZZE E DEHORS**  
*PARTICULARLY SUITABLE FOR HOTELS, BARS, RESTAURANTS, TERRACES AND OUTDOOR SEATING AREAS*
- **MONTAGGIO A SOFFITTO**  
*CEILING MOUNTING*
- **ACCENSIONE ISTANTANEA, SENZA TEMPI DI PRERISCALDAMENTO**  
*INSTANT IGNITION, NO PREHEATING REQUIRED*
- **CONTROLLO TOTALE TRAMITE TELECOMANDO INCLUSO (LE BATTERIE NON SONO INCLUSE)**  
*FULL CONTROL VIA REMOTE CONTROL (BATTERIES NOT INCLUDED)*
- **LAMPADA LOW GLARING ANTIABBAGLIAMENTO E ANTIRIFLESSO**  
*LOW GLARING AND ANTI-REFLECTIVE LAMP*
- **TIMER PROGRAMMABILE PER SPEGNIMENTO AUTOMATICO**  
*PROGRAMMABLE TIMER FOR AUTOMATIC SWITCH-OFF*
- **KIT COMPOSTO DA 2 RISCALDATORI PARETE E LE "STAFFE-GEMELLE-RISCALDATORE"**  
*KIT CONSISTING OF 2 WALL HEATERS AND HEATER BRACKET*



### PARTICOLARITÀ / SPECIAL FEATURE

**LA LUCE NON COLPISCE DIRETTAMENTE GLI OCCHI PERCHÉ VIENE RIFLESSA DA UNO SPECCHIO CURVO CHE CONSENTE DI CONCENTRARE IL CALORE IN MODO PRECISO SOLO VERSO LA ZONA DESIDERATA**

*THE LIGHT DOES NOT STRIKE THE EYES DIRECTLY BECAUSE IT IS REFLECTED BY A CURVED MIRROR THAT ALLOWS THE HEAT TO BE CONCENTRATED PRECISELY ON THE DESIRED AREA AVOIDING DISPERSION AND OPTIMISING ENERGY CONSUMPTION*



EU directives compliance  
LVD 2014/35/UE EMC 2014/30/UE  
DERP 2009/125/CE  
RoHS 2011/65/EU ((UE) 2015/863)

# STUFA-INFRAROSSI-TERRA



STOCK

2000 8025431012288

4000 8025431016644

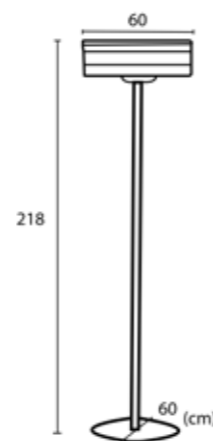

## CARATTERISTICHE/FEATURES

- **RISCALDATORE INFRAROSSI DI DESIGN ONDA CORTA IR-A / SHORTWAVE INFRARED HEATER**
- **MATERIALE: ALLUMINIO / MATERIAL: ALUMINIUM**
- **DIMENSIONI / DIMENSIONS 218X60X60 CM**
- **PESO / WEIGHT 21,5 KG**
- **POTENZA 2000W REGOLABILE SU 3 LIVELLI / POWER 2000W ADJUSTABLE TO 3 LEVELS**
- **TECNOLOGIA A INFRAROSSI A ONDE CORTE IR-A, CALORE IMMEDIATO**  
*SHORTWAVE IR-A INFRARED TECHNOLOGY, INSTANT HEAT*
- **PARTICOLARMENTE ADATTO PER HOTEL, BAR, RISTORANTI, TERRAZZE E DEHORS**  
*PARTICULARLY SUITABLE FOR HOTELS, BARS, RESTAURANTS, TERRACES AND OUTDOOR SEATING AREAS*
- **MONTAGGIO A PARETE O CON PIEDISTALLO OPZIONALE**  
*WALL MOUNTING OR WITH OPTIONAL PEDESTAL*
- **ACCENSIONE ISTANTANEA, SENZA TEMPI DI PRERISCALDAMENTO**  
*INSTANT IGNITION, NO PREHEATING REQUIRED*
- **CONTROLLO TOTALE TRAMITE TELECOMANDO INCLUSO (LE BATTERIE NON SONO INCLUSE)**  
*FULL CONTROL VIA REMOTE CONTROL (BATTERIES NOT INCLUDED)*
- **LAMPADA LOW GLARING ANTIABBAGLIAMENTO E ANTIRIFLESSO**  
*LOW GLARING AND ANTI-REFLECTIVE LAMP*
- **TIMER PROGRAMMABILE PER SPEGNIMENTO AUTOMATICO**  
*PROGRAMMABLE TIMER FOR AUTOMATIC SWITCH-OFF*
- **IL PALO ANTIRIBALTAMENTO CONSENTE DI POSIZIONARE FACILMENTE IL RISCALDATORE DOVE SERVE DI PIU'**  
*THE ANTI-TIP POLE ALLOWS YOU TO EASILY POSITION THE HEATER WHERE IT IS MOST NEEDED*



### PARTICOLARITÀ / SPECIAL FEATURE

**LA LUCE NON COLPISCE DIRETTAMENTE GLI OCCHI PERCHÉ VIENE RIFLESSA DA UNO SPECCHIO CURVO CHE CONSENTE DI CONCENTRARE IL CALORE IN MODO PRECISO SOLO VERSO LA ZONA DESIDERATA**

*THE LIGHT DOES NOT STRIKE THE EYES DIRECTLY BECAUSE IT IS REFLECTED BY A CURVED MIRROR THAT ALLOWS THE HEAT TO BE CONCENTRATED PRECISELY ON THE DESIRED AREA AVOIDING DISPERSION AND OPTIMISING ENERGY CONSUMPTION*



EU directives compliance  
LVD 2014/35/UE EMC 2014/30/UE  
DERP 2009/125/CE  
RoHS 2011/65/EU ((UE) 2015/863)

# STAFFE-GEMELLE-RISCALDATORE

8025431012325

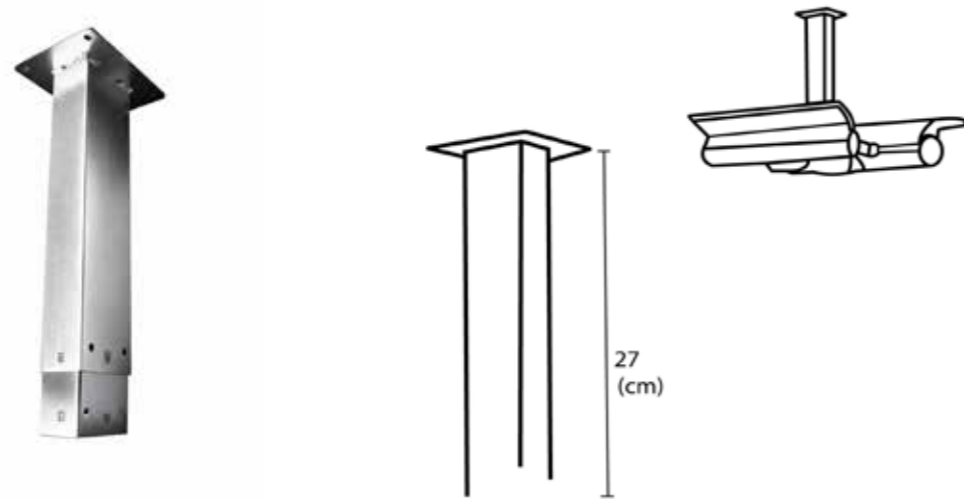

## CARATTERISTICHE/FEATURES

- **SUPPORTO DA SOFFITTO PER INFRAROSSI**  
*INFRARED CEILING MOUNT*
- **MATERIALE: ACCIAIO 304/ MATERIAL: STAINLESS STEEL 304**
- **DIMENSIONI/DIMENSIONS 218X60X60 CM**
- **PESO/WEIGHT 18 KG**
- **È POSSIBILE APPENDERNE DUE ALLA VOLTA / TWO CAN BE HUNG AT A TIME**
- **PARTICOLARMENTE ADATTO PER HOTEL, BAR, RISTORANTI, TERRAZZE E DEHORS**  
*PARTICULARLY SUITABLE FOR HOTELS, BARS, RESTAURANTS, TERRACES AND OUTDOOR SEATING AREAS*
- **È ESTENSIBILE, DA 30 A 60 CM / EXTENDABLE, FROM 30 TO 60 CM**



EU directives compliance  
LVD 2014/35/UE EMC 2014/30/UE  
DERP 2009/125/CE  
RoHS 2011/65/EU ((UE) 2015/863)



# SUPPORTO-RISCALDATORE

8025431016651



## CARATTERISTICHE/FEATURES

- **PALO SUPPORTO RISCALDATORE**  
*HEATER SUPPORT*
- **MATERIALE: ACCIAIO 304 / MATERIAL: STAINLESS STEEL 304**
- **DIMENSIONI/DIMENSIONS 218X60X60 CM**
- **PESO/WEIGHT 18 KG**
- **COMPATIBLE CON DIVERSI MODELLI / COMPATIBLE WITH MULTIPLE MODELS**
- **PARTICOLARMENTE ADATTO PER HOTEL, BAR, RISTORANTI, TERRAZZE E DEHORS**  
*PARTICULARLY SUITABLE FOR HOTELS, BARS, RESTAURANTS, TERRACES AND OUTDOOR SEATING AREAS*
- **BASE ANTIRIBALTAMENTO Ø 60CM / ANTI-TIP BASE Ø 60CM**
- **IL PALO VIENE FORNITO IN 3 PARTI CHE SI AVVITANO INSIEME**  
*THE POLE IS SUPPLIED IN 3 PARTS THAT SCREW TOGETHER.*
- **IL PALO ANTIRIBALTAMENTO CONSENTE DI POSIZIONARE FACILMENTE IL RISCALDATORE DOVE SERVE DI PIU'**  
*THE ANTI-TIP POLE ALLOWS YOU TO EASILY POSITION THE HEATER WHERE IT IS MOST NEEDED*



EU directives compliance  
LVD 2014/35/UE EMC 2014/30/UE  
DERP 2009/125/CE  
RoHS 2011/65/EU ((UE) 2015/863)



# CALORE-BIANCO

STOCK



<b>1500</b>	8025431012240	104,5 CM
<b>1800</b>	8025431012257	122,5 CM
<b>2400</b>	8025431012264	150,5 CM

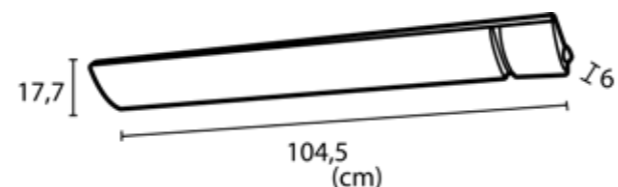

## CARATTERISTICHE/FEATURES

- **RISCALDATORE INFRAROSSI ONDA LUNGA IR-C / IR-C LONG WAVE INFRARED HEATER**
- **MATERIALE: ALLUMINIO / MATERIAL: ALUMINIUM**
- **PESO/WEIGHT 5,4/6,1/7,5 KG**
- **POTENZA 1500-2400W / POWER 1500-2400W**
- **TECNOLOGIA A INFRAROSSI A ONDA LUNGA IR-C  
SHORTWAVE IR-A INFRARED TECHNOLOGY**
- **PARTICOLARMENTE INDICATO PER TERRAZZE CHIUSE CON VETRI O PLASTIC, PERGOLE BIOCLIMATICHE, SAUNE E CENTRI MASSAGGIO  
PARTICULARLY SUITABLE FOR TERRACES ENCLOSED WITH GLASS OR PLASTIC, BIOCLIMATIC PERGOLAS, SAUNAS AND MASSAGE CENTRES**
- **INSTALLAZIONE A PARETE O A SOFFITTO CON LE STAFFE REGOLABILE INCLUSE  
WALL OR CEILING INSTALLATION WITH ADJUSTABLE BRACKETS INCLUDED**
- **CONTROLLO TOTALE TRAMITE TELECOMANDO INCLUSO (LE BATTERIE NON SONO INCLUSE)  
FULL CONTROL VIA REMOTE CONTROL (BATTERIES NOT INCLUDED)**
- **RIVESTIMENTO CERAMICO BIANCO NANO TECNOLOGICO CHE NON DIVENTA GIALLO NEL TEMPO  
WHITE NANO-TECHNOLOGICAL CERAMIC COATING THAT DOES NOT YELLOW OVER TIME**
- **INCLUDE CAVO 110CM, COLLEGATO A DESTRA E SPINA SCHUKO  
INCLUDES 110 CM CABLE, CONNECTED ON THE RIGHT AND SCHUKO PLUG**

### PARTICOLARITÀ / SPECIAL FEATURE

**IL RISCALDAMENTO RADIANTE A ONDA LUNGA FAVORISCE LA CIRCOLAZIONE SANGUIGNA E IL METABOLISMO, OFFRENDO BENEFICI FISICI E GARANTENDO SICUREZZA PER GLI UTILIZZATORI**  
LONG-WAVE RADIANT HEATING PROMOTES BLOOD CIRCULATION AND METABOLISM, OFFERING PHYSICAL BENEFITS AND ENSURING SAFETY FOR USERS.



EU directives compliance  
LVD 2014/35/UE      EMC 2014/30/UE  
DERP 2009/125/CE  
RoHS 2011/65/EU ((UE) 2015/863)

# CALORE-NERO

STOCK \*fino ad esaurimento scorte

1500 8025431016521 104,5 CM

1800 8025431016538 122,5 CM

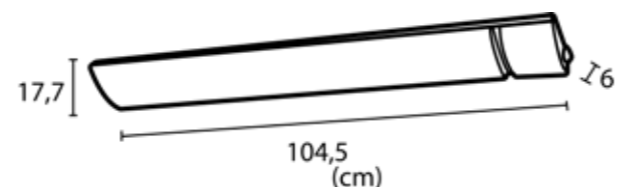

## CARATTERISTICHE/FEATURES

- **RISCALDATORE INFRAROSSI ONDA LUNGA IR-C / IR-C LONG WAVE INFRARED HEATER**
- **MATERIALE: ALLUMINIO/ MATERIAL: ALUMINIUM**
- **PESO/WEIGHT 5,4/6,1/7,5 KG**
- **POTENZA 1500-1800W / POWER 1500-1800W**
- **TECNOLOGIA A INFRAROSSI A ONDA LUNGA IR-C  
SHORTWAVE IR-A INFRARED TECHNOLOGY**
- **PARTICOLARMENTE INDICATO PER TERRAZZE CHIUSE CON VETRI O PLASTIC, PERGOLE  
BIOCLIMATICHE, SAUNE E CENTRI MASSAGGIO  
PARTICULARLY SUITABLE FOR TERRACES ENCLOSED WITH GLASS OR PLASTIC, BIOCLIMATIC  
PERGOLAS, SAUNAS AND MASSAGE CENTRES**
- **INSTALLAZIONE A PARETE O A SOFFITTO CON LE STAFFE REGOLABILE INCLUSE  
WALL OR CEILING INSTALLATION WITH ADJUSTABLE BRACKETS INCLUDED**
- **CONTROLLO TOTALE TRAMITE TELECOMANDO INCLUSO (LE BATTERIE NON SONO INCLUSE)  
FULL CONTROL VIA REMOTE CONTROL (BATTERIES NOT INCLUDED)**
- **INCLUDE CAVO 110CM, COLLEGATO A DESTRA E SPINA SCHUKO  
INCLUDES 110 CM CABLE, CONNECTED ON THE RIGHT AND SCHUKO PLUG**

### PARTICOLARITÀ / SPECIAL FEATURE

**IL RISCALDAMENTO RADIANTE A ONDA LUNGA FAVORISCE LA  
CIRCOLAZIONE SANGUIGNA E IL METABOLISMO, OFFRENDO  
BENEFICI FISICI E GARANTENDO SICUREZZA PER GLI  
UTILIZZATORI**  
*LONG-WAVE RADIANT HEATING PROMOTES BLOOD CIRCULATION  
AND METABOLISM, OFFERING PHYSICAL BENEFITS AND ENSURING  
SAFETY FOR USERS.*



EU directives compliance  
LVD 2014/35/UE EMC 2014/30/UE  
DERP 2009/125/CE  
RoHS 2011/65/EU ((UE) 2015/863)

# CALORE-NERO-WIFI

STOCK

1500	8025431018907	104,5 CM
1800	8025431018914	122,5 CM
2400	8025431018921	150,5 CM
3200	8025431018938	191,5 CM

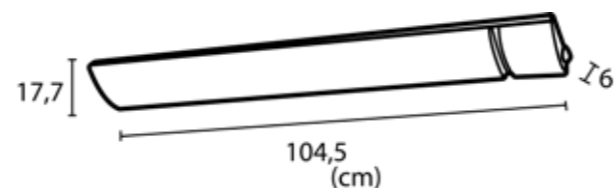

## CARATTERISTICHE/FEATURES

- **RISCALDATORE INFRAROSSI ONDA LUNGA IR-C / IR-C LONG WAVE INFRARED HEATER**
- **MATERIALE: ALLUMINIO / MATERIAL: ALUMINIUM**
- **PESO/WEIGHT 5,4/6,1/7,5/9,5 KG**
- **POTENZA 1500-3200W / POWER 1500-3200W**
- **TECNOLOGIA A INFRAROSSI A ONDA LUNGA IR-C  
SHORTWAVE IR-A INFRARED TECHNOLOGY**
- **PARTICOLARMENTE INDICATO PER TERRAZZE CHIUSE CON VETRI O PLASTIC, PERGOLE  
BIOCLIMATICHE, SAUNE E CENTRI MASSAGGIO  
PARTICULARLY SUITABLE FOR TERRACES ENCLOSED WITH GLASS OR PLASTIC, BIOCLIMATIC  
PERGOLAS, SAUNAS AND MASSAGE CENTRES**
- **INSTALLAZIONE A PARETE O A SOFFITTO CON LE STAFFE REGOLABILE INCLUSE  
WALL OR CEILING INSTALLATION WITH ADJUSTABLE BRACKETS INCLUDED**
- **CONTROLLO TOTALE TRAMITE TELECOMANDO INCLUSO (LE BATTERIE NON SONO INCLUSE)  
FULL CONTROL VIA REMOTE CONTROL (BATTERIES NOT INCLUDED)**
- **INCLUDE CAVO 110CM, COLLEGATO A DESTRA E SPINA SCHUKO  
INCLUDES 110 CM CABLE, CONNECTED ON THE RIGHT AND SCHUKO PLUG**
- **WIFI APP TUYA**

### PARTICOLARITÀ / SPECIAL FEATURE

**IL RISCALDAMENTO RADIANTE A ONDA LUNGA FAVORISCE LA CIRCOLAZIONE SANGUIGNA E IL METABOLISMO, OFFRENDO BENEFICI FISICI E GARANTENDO SICUREZZA PER GLI UTILIZZATORI**  
LONG-WAVE RADIANT HEATING PROMOTES BLOOD CIRCULATION AND METABOLISM, OFFERING PHYSICAL BENEFITS AND ENSURING SAFETY FOR USERS.



EU directives compliance  
LVD 2014/35/UE EMC 2014/30/UE  
DERP 2009/125/CE  
RoHS 2011/65/EU ((UE) 2015/863)

# RISCALDATORE INFRAROSSI 4000 INDUSTRIAL



## CARATTERISTICHE/FEATURES

- **RISCALDATORE INFRAROSSI ONDA LUNGHE A7 IR-C / A7 IR-C LONG WAVE INFRARED HEATER**
- **MATERIALE: ALLUMINIO/ MATERIAL: ALUMINIUM**
- **DIMENSIONI/DIMENSIONS 208X25X14,5 CM**
- **PESO/WEIGHT 11,4 KG**
- **POTENZA 4000W 380V TRIFASE / POWER 4000W 380V THREE-PHASE**
- **TECNOLOGIA A INFRAROSSI A ONDA LUNGHE A7 IR-C  
SHORTWAVE IR-A INFRARED TECHNOLOGY**
- **PERFETTO PER CAPANNONI, BAR, ALBERGHI, SERRE, ALLEVAMENTI, PALESTRE, HOTEL,  
CHIESE E UFFICI  
PERFECT FOR WAREHOUSES, BARS, HOTELS, GREENHOUSES, GYMS, CHURCHES, AND OFFICES**
- **INSTALLAZIONE A PARETE O A SOFFITTO ANCHE CON CATENE  
WALL OR CEILING INSTALLATION, ALSO WITH CHAINS**
- **IL COLLEGAMENTO ELETTRICO DEVE ESSERE EFFETTUATO DA UN ELETTRICISTA  
PROFESSIONALE: NON INCLUDE CAVI, SPINE, INTERRUTTORI E TELECOMANDO  
THE ELECTRICAL CONNECTION MUST BE CARRIED OUT BY A PROFESSIONAL ELECTRICIAN: CABLES,  
PLUGS, SWITCHES AND REMOTE CONTROL ARE NOT INCLUDED.**

### **PARTICOLARITÀ / SPECIAL FEATURE**

**IL RISCALDAMENTO RADIANTE A ONDA LUNGA FAVORISCE LA CIRCOLAZIONE SANGUIGNA E IL METABOLISMO, OFFRENDO BENEFICI FISICI E GARANTENDO SICUREZZA PER GLI UTILIZZATORI**

*LONG-WAVE RADIANT HEATING PROMOTES BLOOD CIRCULATION AND METABOLISM, OFFERING PHYSICAL BENEFITS AND ENSURING SAFETY FOR USERS.*



EU directives compliance  
LVD 2014/35/UE EMC 2014/30/UE  
DERP 2009/125/CE  
RoHS 2011/65/EU ((UE) 2015/863)

# SINED PRESENTA LA NUOVA LINEA DI MOBILI CON CAMINETTO INTEGRATO

*"Non è solo un camino. Non è solo un mobile. È un'esperienza d'arredo firmata SINED."*

## Un mercato in trasformazione

Cresce la domanda di **caminetti elettrici** come elemento d'arredo, non solo funzionale.

Sempre più consumatori cercano **soluzioni pronte, pratiche e belle da vedere**, che uniscano comfort, estetica e facilità di installazione.

Il mobile con caminetto integrato risponde a una **nuova esigenza del living moderno**: design + atmosfera + zero vincoli tecnici.

## SINED guida il cambiamento

SINED introduce una nuova linea di mobili pronti con caminetto elettrico integrato, un prodotto che:

- Rende il camino **immediatamente fruibile**
- Abbatte i costi e tempi di installazione.
- Offre una **soluzione plug & play** per arredare ambienti domestici e professionali.
- **Stile moderno e minimale**, come tutta la gamma di prodotti SINED
- Realizzati in **MDF di alta qualità o legno rivestito**, con finiture eleganti
- **Fiamma LED realistica**, con possibilità di **riscaldamento attivabile**.
- Alcuni modelli con **mensole, vani portaoggetti o supporto TV** integrato.

**Vantaggi per il cliente finale sono molteplici**, nessuna opera muraria, **nessun professionista richiesto**. **Un solo acquisto, doppio valore**: camino e mobile in uno. **Perfetto per ogni tipo di ambiente**: soggiorni, camere da letto, home office, reception.

Questa nuova linea rappresenta la **naturale evoluzione** del nostro impegno nel settore dei caminetti elettrici. Con i mobili camino, **SINED risponde in modo unico e distintivo a una richiesta reale e crescente**, offrendo al mercato un prodotto **chiavi in mano**, bello, intelligente e accessibile.



# SINED PRESENTS THE NEW FURNITURE LINE WITH INTEGRATED FIREPLACE

*'It's not just a fireplace. It's not just a piece of furniture. It is a furnishing experience by SINED.'*

## A changing market

There is a growing demand for electric fireplaces as a furnishing element, not just a functional one.

More and more consumers are looking for ready-made, practical and attractive solutions that combine comfort, aesthetics and ease of installation.

Furniture with an integrated fireplace responds to a new need in modern living: design + atmosphere + zero technical constraints.

## SINED drives change

SINED introduces a new line of ready-made furniture with an integrated electric fireplace, a product that:

- Makes the fireplace **immediately usable**
- Cuts installation costs and time
- Offers a **plug & play solution** for furnishing domestic and professional environments.
- **Modern and minimalist style**, like the entire SINED product range
- Made of **high quality MDF or coated wood**, with elegant finish
- **Realistic LED flame**, with switchable **heating option**.
- Some models with **shelves, storage compartments or integrated TV stand**.

**Advantages for the end customer are manifold**, no masonry work, **no professional required**. **One purchase, double value**: fireplace and furniture in one. **Perfect for any type of environment**: living rooms, bedrooms, home office, reception..

This new line represents the **natural evolution** of our commitment to electric fireplaces. With its fireplace furniture, **SINED is responding in a unique and distinctive way to a real and growing demand**, offering the market a beautiful, intelligent and affordable turnkey product.



# PARETI ATTREZZATE “CINEWALL” SU MISURA CON CAMINETTI

Su richiesta progettiamo e realizziamo **mobili e pareti attrezzate su misura per caminetti**, pensate per integrarsi perfettamente in qualsiasi ambiente.

Ogni progetto viene sviluppato in **modo personalizzato**, con totale libertà di progettazione, consentendo di scegliere dimensioni, materiali, finiture e configurazione. Una soluzione esclusiva che unisce funzionalità ed estetica, adattandosi sia agli spazi residenziali che contract ed esaltando il camino come elemento centrale dell'ambiente.

Il cliente può semplicemente **inviarci una fotografia e le misure della parete** in cui desidera inserire il caminetto: da lì sviluppiamo un progetto personalizzato, funzionale ed esteticamente coerente con l'ambiente.



# CUSTOMISED CINEWALL FOR FIREPLACES

On request, we design and **manufacture custom-made furniture and walls for fireplaces**, designed to blend perfectly into any environment.

Each project is developed on a bespoke basis, with **complete design freedom**, allowing you to choose the dimensions, materials, finishes and configuration. An exclusive solution that combines functionality and aesthetics, adapting to both residential and contract spaces and enhancing the fireplace as the central element of the environment.

The customer can simply **send us a photograph and the measurements of the wall** where the fireplace will be installed, and we will develop a personalized design that blends functionality and aesthetics.



# CONDIZIONI DI FORNITURA

Crediamo nella qualità e nella durata dei nostri prodotti. Per questo motivo, offriamo una garanzia di 3 anni su tutti i prodotti a marchio SINED.

## 1. INFORMAZIONI GENERALI

### Garanzia del Produttore

- Per "Consumatore" si intende qualsiasi persona fisica o giuridica che sia proprietaria del prodotto e non lo abbia acquistato per rivenderlo o installarlo a terzi nell'esercizio di un'attività commerciale o professionale.
- Per "Cliente Iniziale" o "Rivenditore" si intende il primo acquirente di prodotti a marchio SINED, sia esso un rivenditore o un professionista che rivende o installa il prodotto per terzi nell'ambito della propria attività.

## 2. PERIODO DI GARANZIA

Il periodo di garanzia decorre dalla data di acquisto indicata sulla fattura originale del Cliente Iniziale (Rivenditore).

La garanzia ha una durata di **3 anni** a partire dalla suddetta data, a condizione che:

- La fattura originale venga conservata e mostrata su richiesta;
- Il prodotto sia stato installato e mantenuto da personale qualificato, secondo le istruzioni e le normative in vigore.

## 3. GARANZIA

Per attivare una richiesta di assistenza in garanzia il Consumatore deve:

- Notificare per iscritto il difetto a SINED o al Rivenditore autorizzato;
- Presentare la fattura originale che dimostri la data di acquisto e la validità della garanzia;
- Assicurarsi che l'installazione e la manutenzione siano state effettuate da personale qualificato.

## 4. LIMITAZIONI DELLA GARANZIA

La garanzia **non copre**:

- Parti soggette a normale usura (cartucce, guarnizioni, anelli di tenuta, pompe sapone, filtri, aeratori);
- Danni da installazione errata o da presenza di residui nelle tubature tipo sabbia o calcare.
- Danni causati da sporcizia, calcare, uso improprio, prodotti chimici aggressivi, errori di funzionamento, urti, agenti atmosferici o ambienti estremi.

## 5. DECADENZA DELLA GARANZIA

La garanzia **decade** nei seguenti casi:

- Danni causati da forza maggiore (es. incendi, inondazioni, gelo);
- Uso improprio o non conforme alle istruzioni d'uso;
- Installazione, manutenzione o riparazioni effettuate da personale non qualificato;
- Utilizzo di ricambi non originali SINED;
- Deterioramento da calcare, sovratensioni elettriche, fenomeni atmosferici;
- Manutenzione inadeguata o mancata osservanza delle istruzioni;

**Interventi non coperti:**

- Pulizia filtri;
- Pulizia aeratori;
- Rimozione del calcare da doccette, soffioni o superfici.

In caso di reclami **non fondati** (difetti non imputabili a SINED), **tutti i costi** (accertamento, trasporto, manodopera) saranno addebitati al cliente.

## 6. ESCLUSIONI E COSTI A CARICO DEL CONSUMATORE

Se il difetto non è coperto dalla garanzia:

- I costi di spedizione/trasporto sono a carico del Consumatore;
- Se il Consumatore desidera comunque effettuare la riparazione, dovrà farsi carico dei costi di ricambi e manodopera.

La garanzia **non è rinnovabile e non prevede risarcimenti** per danni diretti o indiretti derivanti da guasti o difetti del prodotto.

## 7. DISPOSIZIONI FINALI

La presente garanzia:

- È trasferibile al futuro proprietario del prodotto solo se Consumatore;
- È soggetta alla legge **italiana**.

# SUPPLY CONDITIONS

We believe in the quality and durability of our products. For this reason, we offer a 3-year warranty on all SINED brand products.

## 1. GENERAL INFORMATION

### Manufacturer's Warranty

- "Consumer" means any natural or legal person who owns the product and has not purchased it to resell or install it to third parties in the course of a commercial or professional activity.
- "Initial Customer" or "Reseller" means the first purchaser of SINED brand products, whether a reseller or a professional who resells or installs the product for third parties in the course of their business.

## 2. WARRANTY PERIOD

The warranty period runs from the date of purchase indicated on the original invoice of the Initial Customer (Reseller).

The warranty lasts for **3 years** from that date, provided that:

- The original invoice is retained and shown upon request;
- The product has been installed and maintained by qualified personnel, according to the instructions and regulations in force.

## 3. WARRANTY

To activate a warranty service request, the Consumer must:

- Notify the defect in writing to SINED or the Authorized Dealer;
- Present the original invoice demonstrating the date of purchase and the validity of the warranty;
- Ensure that installation and maintenance have been carried out by qualified personnel.

## 4. WARRANTY LIMITATIONS

The warranty **does not cover**:

- Parts subject to normal wear (cartridges, gaskets, sealing rings, soap pumps, filters, aerators);
- Damage from incorrect installation or the presence of residues in the pipes such as sand or limescale.
- Damage caused by dirt, limescale, improper use, aggressive chemicals, operating errors, impacts, atmospheric agents or extreme environments.

## 5. WARRANTY VOID

The warranty **lapses** in the following cases:

- Damage caused by force majeure (e.g. fires, floods, frost);
- Improper use or use not in accordance with the instructions for use;
- Installation, maintenance or repairs carried out by unqualified personnel;
- Use of non-original SINED spare parts;
- Deterioration from limescale, electrical surges, atmospheric phenomena;
- Inadequate maintenance or failure to follow the instructions;

**Interventions not covered:**

- Filter cleaning;
- Cleaning aerators;
- Removing limescale from shower heads, shower heads or surfaces.

In the event of **unfounded complaints** (defects not attributable to SINED), **all costs** (assessment, transport, labour) will be charged to the customer.

## 6. EXCLUSIONS AND COSTS TO BE PAID BY THE CONSUMER

If the defect is not covered by the warranty:

- Shipping/transport costs are to be paid by the Consumer;
- If the Consumer still wishes to carry out the repair, he will have to pay the costs of spare parts and labour.

The warranty **is not renewable and does not provide compensation** for direct or indirect damages resulting from faults or defects of the product.

## 7. FINAL PROVISIONS

This warranty:

- Is transferable to the future owner of the product only if a Consumer;
- Is subject to **Italian law**.



**Come trovarci?**  
SINED V.O. S.L.U



Via Trajana 50-56  
Nave 28, San Martí,  
08020 Barcelona





**Italia:**  
**M.P.C. Musso Personal Computer**  
**Via Beatrice d'Este 24**  
**20122 Milano, Italia**  
**IT11811400156**

**España:**  
**Sined Ventas Online S.L.**  
**ESB42784397**

**Oficina, showroom y logística:**  
**Vía Trajana 50-56 Nave 28, Sant Martí,**  
**08020 Barcelona**

CENTRALINO IT +39 02 38260773  
MOBILE IT +39 335 7600875  
MOBILE EN/FR +39 3425447140

CENTRALITA ES +34 935 05 67 23  
TELÉFONO ES/EN +34 664 66 64 26  
TELÉFONO ES/EN +34 664 66 64 28  
TELÉFONO ES/DE/EN +34 661 102 712

INFO@SINEDITALIA.COM

SINEDITALIA.COM  
SINEDITALIA.IT  
SINEDITALIA.ES  
SINEDITALIA.FR

CATALOGO-SINED-DESIGN-FUOCO-2026



CATALOGO SINED 2026